



Construction Site Safety Handbook

Published by

The Real Estate Developers Association of Hong Kong

and

The Hong Kong Construction Association





Disclaimer

The materials contained in this Construction Site Safety Handbook (hereunder 'Handbook') have been developed to provide guidance to interested parties, including contractors and subcontractors, in managing safety and health risks in accordance with the agreed principles of the REDA/HKCA Safety Partnering Programme and the contractual requirements. Every due care has been exercised taking into the account the circumstances of local working environment and requirements of the laws of Hong Kong. Any advice or comment in this Handbook is given in this general context and should not be relied upon as a substitute for legal or other professional advice.

This document is produced to provide practical guidance on managing safety and health on construction sites and to meet legal obligations. There is no intention whatsoever to offer exhaustive guidance and interpretation of the Factories and Industrial Undertakings Ordinance and its subsidiary regulations. Anyone wishing to affirm the legal position of individual facts or situation should refer to the relevant regulations and other related statutory documents or consult a lawyer.

Taking the advice and good management practice given in this document does not confer any immunity from legal obligations, both criminal and civil.

Whilst every effort has been made to ensure the accuracy of the information provided in this Handbook, the author, REDA/HKCA, their agents and the publishers accept no responsibility or liability for any loss or damage caused, whether occasioned by negligence, misstatement or otherwise arising out of any errors, omissions or inaccuracies in the materials.

Copyright

The copyright of this document rests jointly with The Real Estate Developers Association of Hong Kong and the Hong Kong Construction Association. Reproduction of any of its contents for commercial purpose is not allowed.

June 2005.





Table of Contents



Preface	4
Introduction	7
Objectives of this Handbook	7
Use of this Handbook.....	8
CHAPTER 1 Duties of Responsible Persons.....	9
CHAPTER 2 Planning Before Work	12
Pre-work planning:.....	12
Site layout.....	14
Site security	20
Traffic and pedestrian arrangement.....	23
Housekeeping.....	27
Welfare and toilet facilities	39
Site Safety Cycle	44
CHAPTER 3 Controlling Risks	56
Electricity safety.....	57
Hand tools.....	64
Noise control.....	67
Disposal of building debris/waste/rubbish.....	71
Safe access	72
Use of personal protective equipment	73
CHAPTER 4 Foundation Work.....	76
Caisson.....	76
Sheet piling.....	79
Shoring	85
General precaution for safe excavations.....	87
Access/egress	90





CHAPTER 5 Building and Minor Civil Work 100

Slip forms 100
 Tower cranes and lifting operations 107
 Prefabricated formwork 112
 Scaffolds 121
 Working platforms 122
 Suspended working platforms 127
 Material hoist 127
 Temporary works 129
 Ladders 136
 Portable tools 147
 Confined space 150
 Concrete pump 154
 Slope work 155

CHAPTER 6 Maintenance Work 163

Lifts and escalators 166
 Site safety assessment 168
 Working at height 172
 Maintenance of chiller room and water tank 175
 Cooling towers 176
 Asbestos 179
 Source of electricity 181

CHAPTER 7 Renovation Work and Refurbishment 188

Working with solvents and paints 188
 Basic steps in the safe use of solvents and paints 189
 Paint spraying and solvents/paints handling 190
 Loads on scaffolds 194
 Woodworking 199

CHAPTER 8 Demolition 204

CHAPTER 9 Site Management 214

Injury Management 217





Preface



We are pleased to publish a set of four safety management documents to serve as reference for participating companies under a Partnering Programme. It is the first phase of an ambitious programme that has a vision to bring Hong Kong's private sector construction safety performance to match the world's best performers by 2008.

The four reference documents are: *Contractual Provisions for the Pay for Safety Scheme*, *Construction Site Safety Manual*, *Construction Site Safety Handbook* and *A Practical Guide to Construction Site Safety Management*.

We have commissioned K & M Consultancy Company Limited to undertake the drafting of this set of documents. In the production process, we have in mind target users from different backgrounds, such as developers, their project management staff and representative, designers, contractors and their site employees as well as professionals in different disciplines.

Contractual Provisions for the Pay for Safety Scheme sets out the principal features of a client's commitment to pay for safety-related items of expenditure through conditions in a construction contract. It embodies payment for implementing pre-set items in a schedule and incentive payment for achieving excellence. Clients and contractors under the Programme are expected to follow the provisions in this document to realize the Pay for Safety Scheme in a fair and equitable manner.

The Construction Site Safety Manual provides a framework for managing site safety, with an analysis of the statutory provisions and contractual requirements relevant to managing safety from the perspectives of the client and his representative, the designer, the contractor and various professionals in the safety supply chain. The Manual attempts to relate the safety management responsibilities with the management structure of the Buildings Authority's Site Supervision Plan that is also applicable to private sector projects.

The Construction Site Safety Handbook, as the name suggests, is intended to serve as a handy reference to frontline management teams in managing certain critical and accident-prone site safety issues. By drawing on past accident cases, good and bad trade practices, the Handbook aims to provide a basic framework for those who have direct influence over safety performance, with some useful pointers for continuous improvement. There is a Chinese translation of the *Handbook* available for use by frontline supervisors.





A Practical Guide to Construction Site Safety Management takes the safety management issues to the forefront. It is intended to help clients or their representatives monitor the safety performance of their contractors, implement the concept of construction design and management (CDM) and protect the safety and health of the employees assigned to work on the contractor's sites. It will also help to equip contractors and their management teams with the necessary skills to run an effective safety management system.

Together, the four reference documents are intended to fill a knowledge gap for those who are not too familiar with what it takes to raise site safety performance standards. To complement what is in these documents, participating companies under the Programme are expected to attend a series of training modules that will elaborate on areas not fully covered in the guidance materials. This will be the second significant step in grasping the concepts and understanding the best practices promulgated in these documents.

Acknowledgements

The preparation of the four documents was placed under the stewardship of a joint Steering Committee with representatives from the two associations that gave the consultants direction and steer.

We would like to record our acknowledgements and thanks to the following companies and organizations (in alphabetical order) –

- CLP Power Hong Kong Ltd.
- China State Construction Engineering Corporation
- Chuang's Engineering Ltd.
- Environment, Transport and Works Bureau, Hong Kong SAR Government
- Gammon Construction Ltd.
- Hanison Construction Co. Ltd.
- Henderson Land Development Co. Ltd.
- Heng Tat Construction Co. Ltd.
- Hip Hing Construction Co. Ltd.
- Hip Shing Hong
- Hong Kong Housing Authority
- Hong Kong Housing Society
- MTR Corporation Limited
- Occupational Safety and Health Council
- Paul Y. – ITC Construction and Engineering Co. Ltd.





- Sanfield Building Contractors Ltd.
- Sing Fat Construction Co. Ltd.
- Sino Land Co. Ltd.
- Sinowick Engineering Ltd.
- Sun Hung Kai Properties Ltd.
- Swire Properties Limited
- The Hongkong Electric Company, Limited
- Urban Renewal Authority
- Vibro (H. K.) Ltd.
- Wharf Estates Development Ltd.
- Yau Lee Construction Co. Ltd.

Jointly published by
The Real Estate Developers Association of Hong Kong and
The Hong Kong Construction Association.
2005.

© *The Publishers reserve all copyright of this publication.*





Introduction



Developers and their contractors share the same goal of completing a development project on time, within budget and to attain a quality and standard satisfactory to both sides. A 'win-win' situation is to develop a relationship that focuses on the finished product and a partnership that makes the construction process work to the benefit of both parties. In the context of site safety and health, the Real Estate Developers Association of Hong Kong (REDA) and the Hong Kong Construction Association Ltd. (HKCA) have agreed to create a partnership under which both trade bodies will contribute towards achieving specific performance targets within a timeframe by participating companies under a Partnering Programme.

The *Construction Site Safety Handbook* is one of the four safety management documents for reference by participating companies under this Programme. The other three documents are: *Contractual Provisions for the Pay for Safety Scheme*; *The Construction Site Safety Manual* and *A Practical Guide to Construction Site Safety Management*.

Objectives of this Handbook

The main purpose of the Handbook is to explain in plain language how to develop safe work practices and to meet the statutory and common contract requirements in undertaking construction works. It is not intended to cover each and every type of workplace scenario, nor to be used as a pictorial guide of do's and don'ts. The focus is to address the most common – and hence more accident-prone - hazards found in Hong Kong's worksites.

More specifically, the objectives are -

- To fill a knowledge gap on some site safety issues
- To provide handy reference of best practices for frontline management teams
- To offer some site safety management techniques and tools for use.





Use of this Handbook

Contractors who have experience of undertaking public sector projects should be quite familiar with concepts of a site safety plan, risk assessment, safe working method statement and other safety management arrangements, but private sector clients and contractors may not have the same experience and exposure, particularly for the smaller developers and contractors.

This Handbook is a practical guide specifically prepared for use by the construction industry in managing some critical areas of occupational safety and health (OSH) on site, such as

- The duties of responsible persons
- Pre-work planning
- Controlling risks associated with electricity, hand tools, noise, access, debris disposal etc.
- Working in foundation work, building and minor civil work, maintenance work, renovation and demolition work.

Where a contract involves the use of subcontractors, a contractor should be aware that suitable systems of selection and supervision should apply to his subcontractors and specialist contractors. A contract manager should ensure that suitable training and instructions are in place to ensure that nothing falls between the cracks in understanding and actually implementing the safety requirements.

This Handbook provides a framework for frontline management teams to tackle different aspects of site safety, but it is not substitute for complying with the statutory provisions and standards. Some reference is made to good industry practice and different approaches to tackling the same issue under different circumstances. The intention is to strike a balance between pitching above the minimum requirements of the law and best practices as observed in Hong Kong and elsewhere. In this regard, readers can gauge what their fellow clients and contractors have done, and make their own judgment where they can strive for continuous improvements in their safety performance.

In presenting the materials, the layout and contents under each topic are self-contained so that readers can have a ready reference at a glance, without too much cross-referencing.





CHAPTER 1

Duties of Responsible Persons



A successful corporate safety programme should include a clear statement of policy by the client or owner, expressly showing management support for meeting safety objectives and the involvement of different stakeholders in the management system.

Clients

Clients should put safety and health on the top of the agenda along with financial considerations.

To ensure that all contracts are completed on time, on budget and safely, clients should:

- ensure that safety and health is not compromised
- ensure best value as against the lowest cost
- put in place safety and health considerations during the design stage
- have allowed sufficient time and resources for implementing the contractor's safety programme.

Contractors

- Plan emergency routes and exits, traffic routes, danger areas, loading bays, ramps, etc.
- Ensure provision of safe work equipment, with due care to their suitability, selection, safety features, safe use, training and information, inspection and maintenance.
- Provide safe working slope for excavators.
- Design and anchor fork-lift trucks and dump trucks to prevent roll-over or overturn
- Provide suitable safety signs and warning notices
- Provide personal protective equipment, e.g. reflective clothing that should be fit, comfortable and well maintained





- Keep the workplace free from hazards
- Provide suitable communication and information – to let employees know how to protect themselves against hazards
- Conduct regular jobsite safety inspections
- Employ trained first aid personnel on site and/or put in place an emergency response system.

Employees

- Follow all safety rules
- Ensure that all safety features and equipment installed are functioning properly
- Replace damaged or dull hand tools immediately
- Avoid horseplay or other activities that create a hazard
- Stop work when they are unwell or physically not fit to do the job
- Report any unsafe work practice and any injury or accident to the line supervisor

Senior site management

- Inform workers of the risks present and the control measures required
- Evaluate risks that cannot be avoided
- Combat risks at source
- Establish emergency procedures
- Avoid all risks to workers
- Ensure that appropriate training is given

Architects, structural engineers, and other designers

- Discuss and agree the safety and health terms with client
- Plan for safety and health in layout and design drawings, with due regard to buildability, future maintenance and repairs
- Provide information about the safety and health risk of the design after the client has decided on which contractor(s) to use
- Carry out periodic checks and sort out interface problems with different contractors
- Certify contractor's claims for safety payment and conclude the final accounts.





Safety professionals and supervisors

- Identify hazards in the workplace
- Give advice and suggest options for solving safety or health problems
- Suggest different kinds of help available, such as specialists in chemical, electrical and mechanical engineering safety to sort out issues at stake
- Investigate accidents/incidents and recommend remedial measures
- Carry out periodic checks and provide a written report summarizing the findings
- Develop and maintain an effective safety and health programme
- Provide safety training for employees





CHAPTER 2

Planning Before Work



Pre-work planning:

- A health & safety plan
- An OH&S policy displayed
- An accident report book
- Induction training records
- Workplace inspection records
- Documented safe working procedures or method statements
- Protective clothing & equipment records
- Material safety data sheets (MSDS) available
- Health & safety system manual
- Health and safety representatives appointed including management safety representative
- Contract-specific risk assessment conducted
- Emergency procedures and necessary training records

For small worksites or construction projects, look for the dangers on site (not as a substitute for a full risk assessment) and take the following preventive actions:

- Ensure that dangerous substances on site are being properly stored and used
- Provide and ensure that all persons on site wear proper personal protection equipment
- Identify ways that a risk can be controlled without using personal protective equipment (PPE)
- Ensure that workers are using the right and fit PPE for the job





- Check all plant, machinery and equipment (including PPE) are marked and correctly labeled, e.g. Safe Working Load
- Fence the site against unauthorized entry
- Take measures to prevent objects from falling from height and to take measures to protect members of the public (such as persons passing by the site)
- Provide and keep safe egress and access to the place of work, such as access to scaffolding
- Put up appropriate signs including traffic routes, authorized personnel only etc.
- Keep the site tidy, well lit and well laid out
- Provide sufficient welfare and first aid facilities
- Provide adequate fire precautions such as fire extinguishers, escape routes
- Ensure that existing power lines (buried or overhead) are identified and associated safe systems of work in place
- Take necessary precautions to ensure that electrical systems are well maintained in a safe condition
- Ensure that vehicles and people are kept apart, especially slewing vehicles, with traffic routes maintained in a safe condition
- Ensure that vehicle and plant operators are suitably trained or licensed if required
- Ensure that hoists and lifting appliances are properly installed and checked by competent persons
- Ensure that scaffolds are erected, altered and dismantled by competent people only
- Take measures to stop workers from falling and ensure fall protection
- Minimize and eliminate risk of manual handling by the use of mechanical equipment, or arrange material to be supplied in manageable sizes and weights to reduce the risk of back injury
- Take all measures to reduce exposure to noise and vibration
- Ensure that holes are protected, with clear marking and fixed covers to prevent falls





- Ensure that excavations are adequately supported or otherwise constructed to minimize the risk of collapse and arrange regular inspection by a competent person.

Site layout

- Plan emergency routes and exits, traffic routes, danger areas, loading bays, ramps, etc.
- Ensure provision of safe plant and equipment, with due care to suitability, selection, safety features, safe use, training and information, inspection and maintenance.
- Provide safe working slope for excavators, fork-lift trucks and dump trucks
- Provide suitable safety signs and warning notices

Environmental friendly site hoardings facing main road



Well-planned site layout and process flow control at the planning stage





Safety notices on the information bulletin board at the worksite entrance



Covered walkway adjacent to the worksite



Protection from falling objects at a neighbouring car park close to the worksite





Public protection against falling objects



Clean and neat design at the entrance

Checking point to prevent unauthorized persons

Drop bar to facilitate security check



Warning signs and control system to check workers' identity and valid work certificates before entry





Maintenance of visitor's log system to check unauthorized entry

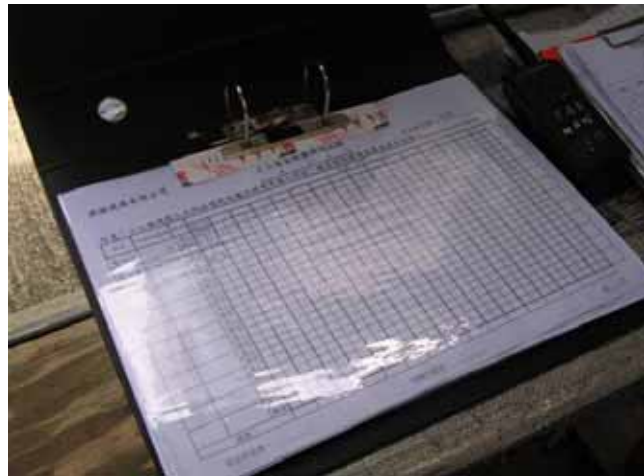

Effective wheel washing facilities provided at site entrance

Water jet to spray off loose mud

Steel bar grit below to remove stiffer mud from the wheels



Temporary loading and unloading area





Proper selection of lifting appliances and gears to ensure safe lifting from the temporary loading area to the upper floors



Retractable overhead protection net - fully retracted when lifting operation is required.

Net fully collapsed to facilitate lifting of materials to upper floors



Retractable overhead protection net – fully extended when lifting operation is not in progress.

Net fully extended to protect workers working in the yard





Steel sections stacked on the site for forming the mega-columns

Temporary stacking yard for steel sections



Work stations around the sides of the cofferdam on ground level, forming a base to serve construction activities inside the cofferdam

Fencing along the perimeters



Temporary storage yard for non-perishable building materials on one side of the worksite





Site security

- Erect suitable barricades, fencing, and hoarding
- Proper signage and lighting in suitable places when passers-by or entry by public is likely
- Footpaths kept clean and free from debris
- Site access controlled
- Traffic control procedures in place

Clear passageway
(rubbish-free and well-lit)



Site security entrance with
turnstiles and security guard
booth





Biometric hand reader for more accurate access control

Biometric hand reader for security checking



Finger Print Machine at site entrance



TV monitoring and videotaping for public access at the guard house





Site entrance with fencing and height control I-beam to prevent contact with overhead cables

Horizontal beam to check height restrictions for incoming vehicles



Warning traffic light

Raised arm barrier system for access control at site entrance



Storage area for personal belongings, helmets & PPE, etc.

Temporary working desk for security people to check safety helmets



Security check desk





Traffic and pedestrian arrangement

The first step is a suitable and sufficient risk assessment. Ask such questions as 'What might go wrong and why?', 'Could people be struck or run over?' and 'Could they lose balance and fall while loading and unloading?'

- Identify the hazards associated with activities involving workplace vehicles, e.g. reversing operations, loading and unloading
- Identify who might be harmed by each hazard. This is likely to include drivers and other workers, and may also include visitors and the public
- Evaluate the risks for each hazard and the likelihood of the harm and its severity. Are existing precautions adequate or should more be done?
- Set priorities for action and implementation
- Review the risk assessment periodically, especially when there are changes, e.g. new vehicles, changes of traffic routes

To start with, consider collective measures to eliminate risks, such as:

- improved design and layout of the workplace to minimize transport accidents
- signs to be used as a secondary measure where risks cannot be eliminated





Considerations during risk assessment and selection of prevention measures

Maintain a system of work by:

- avoiding the need for reversing by better layout design
- using a safe system of work for reversing
- ensuring a safe system of work for loading and unloading vehicles
- checking to see if the layout of routes is appropriate for vehicle and pedestrian activities
- segregating pedestrian and vehicle traffic routes if feasible
- posting adequate warnings in conspicuous places
- ensuring suitable pedestrian crossing points on vehicle routes
- introducing a one-way traffic system, if possible, to reduce the risk of head-on collision
- checking to see if vehicle traffic routes are suitable for the types and flow of vehicles that use them
- keeping all floor and road surfaces in good condition
- removing obstructions or otherwise, making sure they are clearly visible
- avoiding sharp bends in road layouts
- providing suitable fixed mirrors at blind corners

Other measures should also be considered:

- suitable direction, speed limit and priority signs
- suitable physical speed restrictions such as speed bumps
- edges of loading bays, pits etc must be clearly marked and fitted with either a temporary or permanent barrier
- ensure that all vehicles are properly maintained

All drivers should be instructed and reminded that they should –

- not drive when their physical abilities are impaired, e.g. by ill health or poor vision
- be conversant with operating procedures and understand the safe operating limits of vehicles
- carry out daily checks and report all problems





- understand and comply with site rules and procedures, including those for emergencies
- understand the current system of signals
- keep the vehicle within safe speed limits
- slow down and take special care when approaching bends
- use visibility aids such as mirrors or a signaller before reversing to check for pedestrians, vehicles or obstructions behind the vehicle if there is restricted visibility from driving position
- STOP whenever the signaller is out of sight or the visibility aid becomes defective
- turn the engine off before making any adjustments or removing guards

Mirror at blind spot & 'No parking' warning notice



Main traffic route separated from site personnel also serves as main emergency route





Sharp edge covers on both sides of the access



Properly fenced vehicle access/egress with slip protection

Speed limit sign.

Speed limit sign.



Properly fenced workers' access/egress with slip protection





Housekeeping

- Keep work areas free from rubbish and obstructions
- Maintain all floor surfaces safe, suitable and free from slip or trip hazards
- Ensure floor openings covered or otherwise fenced off
- Materials are properly stacked and stored safely

Keep all passageways in good conditions:

- Unobstructed and clearly defined
- Provide adequate lighting
- Ensure clear sightline at breaks and corners

Are lightings maintained in good working order?

- Adequate and free from glare
- Lighting clean and efficient
- No flickering
- Maintain steady lights
- Provide and maintain all emergency lighting systems

Is workers' access to worksites well-maintained?

- Keep all walkways and stairways clear of debris and other materials such as used boxes, wooden scrap, loose gravel, oil leakage, tools and supplies to prevent tripping and slipping
- Put them in a bin or debris area to prevent fire and tripping hazards
- Provide adequate lighting to prevent accidents





Stacking of all materials:

- Ensure the proper heights and correct stacking
- Allow sufficient space for moving stock
- Store materials in racks/bins
- Keep shelves free of rubbish
- Keep floors around stacks and racks clear
- Check drums and ensure pallets in good repair
- Heavier items stored low and without danger of falling objects
- Avoid sharp edges and provide safe means of accessing high shelves

Maintain all stairs, steps and landings:

- Replace or remove worn-out or broken steps
- Keep handrails and fencings in good repair
- Keep clear of all obstructions
- Maintain adequate lighting
- Provide and maintain emergency lighting
- Ensure non-slip treatment/treads in good condition
- Keep clear of debris and spills

Keep your fire control well in place:

- Ensure all extinguishers and fire fighting equipment serviced and marked
- Provide adequate fire alarm and communication system
- Restrict smoking/naked flame
- Avoid storage of excess quantities of flammable substances at worksites
- Establish storage procedures for flammable substances
- Employ and train emergency personnel
- Ensure emergency procedures are documented and issued
- Display emergency telephone numbers
- Conduct regular fire alarm checks
- Perform periodic testing and trial evacuations





Steps for effective fire prevention:

- Provide fire extinguishers near all welding, oxy-acetylene cutting or other sources of ignition
- Keep fire extinguishers easy to locate and reach in case of an emergency
- Never store flammable or combustible materials in common areas, stairways or exits
- Avoid spraying of paint, solvents, or other types of flammable substances in areas with poor ventilation to avoid build-up of fumes and vapors leading to explosions or fires
- Store gasoline and other flammable liquids in a safety can in a ventilated place or an approved storage facility
- Ensure that leaks or spills of flammable or combustible materials are cleaned up promptly

On-site dangerous goods (DG) storage

Safety communication and precautions



Suitable fire extinguisher





On-site dangerous goods storage

Temporary DG cabinets.



On-site dangerous goods storage

Temporary DG cabinets.



Proper stacking of materials





Proper stacking in a temporary storage area



Proper stacking of building materials



Safe access





Safe access with enclosed stairway



Well-protected staircase



Clear and separate passageway





Clear and separate passageway



Clear and separate passageway



Environmentally friendly rubbish bins





Clean and rubbish free floors to prevent dust and falling objects over the floor edges



Cleaner assigned to clean the floor area to keep the site environment clean

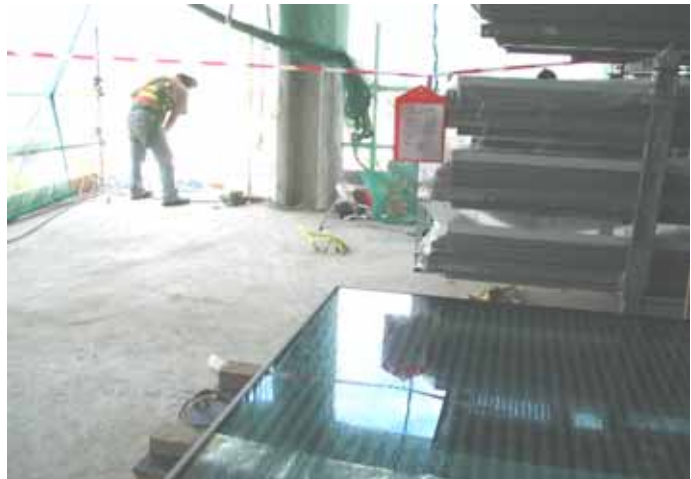

Shoes cleaning bath with gravel bed





Bundled tray to prevent spillage from the container



Mosquito inhibitors to maintain healthy environment



Pre-planned site office with adequate lighting and covered floor surface





Regular spraying of antiseptic solutions to prevent mosquitoes and spread of disease, e.g. Dengue fevers, meningococemia, etc.



Portable fire extinguishers at prominent positions



Fire extinguisher and sand





Fire hose reel



Fire alarm bells at prominent locations



Regular fire drills at the worksite





Workers being trained as fire fighter at the worksite



Worker practicing the use of fire extinguisher



Workers' canteen used as a temporary assembly area during a fire drill





Fire warden to conduct headcount



Welfare and toilet facilities

Welfare and toilet facilities need to be considered in both the pre-tender and construction phases as part of the health and safety plan.

Matters to be considered when planning the welfare and toilet facilities include:

- the work to be carried out and the health risks associated with it
- the duration and spread of the site locations
- the number of people working at different locations
- the distance from rest places and welfare facilities

Welfare facilities also include washing facilities, changing areas, drinking water and eating facilities. In addition, regular maintenance and cleaning will be required, e.g. sewer maintenance work may require the provision of additional washing and changing facilities because of its obnoxious nature.

Toilet facilities

- Fixed installation:
 - at the site base, usually near the site office
 - at different satellite locations, especially when the coverage of worksite is wide and far from the base
- Portable installation on the worksite





Washing facilities

At suitable positions:

- hand basins or bowls
- water tap with buckets or receptacles
- shower or eye-bath where necessary.

Rest areas

- Fixed installation:
 - at the site base location
 - at different satellite locations
- Temporary installations on the worksite

Toilet & washing facilities converted from a container



Regular maintenance of toilet bowls and hand wash basins





Portable toilets provided on the topmost floor under construction



Drinking water and hand wash basin



Hand sterilization facilities to promote hygiene





Vending machines installed at rest area



Shower facilities installed at base location



Cold and hot water facilities at workers' rest area





Workers' rest areas with dining tables and benches



Cigarette butts receptacle with sand bed provided at the rest area



Container provided on worksite for subcontractors' work and rest





Locker room for storage of PPE and workers' apparels



Good housekeeping



Site Safety Cycle

The "Site Safety Cycle" arrangement is modeled on the Japanese practice of "Safety Work Cycle" which encourages active participation of, and communication among, site staff at all levels with a view to promoting safety and tidiness of construction sites. It is done through a so-called '5-S' system.

The term "5-S" comes from a formal system created by the Japanese and adapted by many companies in Hong Kong. The 5 steps in Japanese are *Seiri*, *Seiton*, *Seison*, *Seiketsu* and *Shitsuke*. It is a set of principles and methodology of organization and standardization that goes well beyond normal housekeeping programmes, and sets





the foundation for upkeep and improving the work environment.

What '5-S' means (directly translated from Japanese) is:

- organisation (Seiri)
- neatness (Seiton)
- cleaning (Seiso)
- standardisation (Seiketsu)
- discipline (Shitsuke)

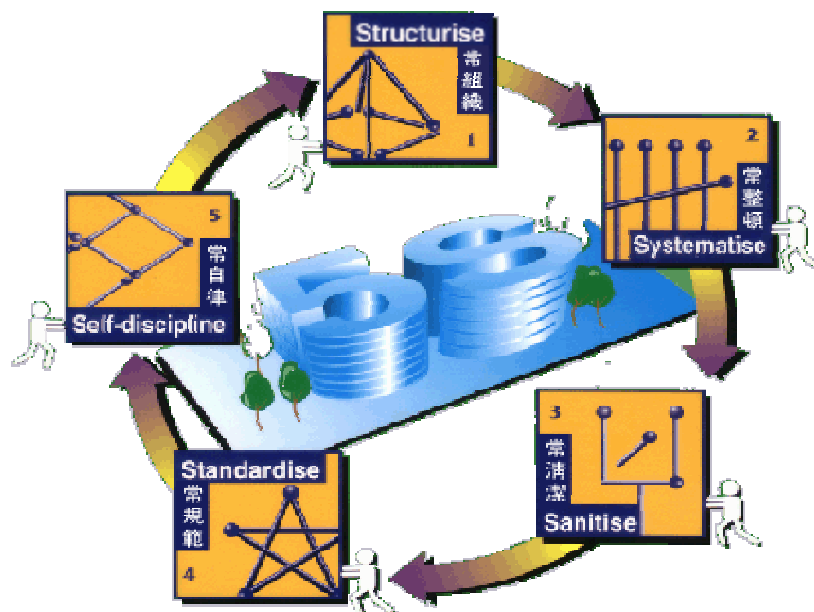

Safety Work Cycle

Source: OSHC's Green Cross

With years of practice, The Japan International Center for Occupational Safety and Health (JICOSH), which was established in July 1999 by the Ministry of Health, Labor and, Welfare together with the Japan Industrial Safety and Health Association (JISHA), still adopt the Safety Work Cycle (SWC) to promote construction safety cycle activities. All parties concerned, in particular the contractors, accepted its importance and usefulness in assigning responsibilities for their operation by reminding workers of the value of exercise and preparedness of risks at the beginning of each shift in the worksite.





The JISHA general guidelines for construction site safety management by Master Employer (1995) set out the implementation of such safety and health arrangements before the start of work. Under this arrangement, the related subcontractors are required to assemble their employees before the start of work every day and make safety and health arrangements concerning the following matter: -

- Providing instructions to related workers concerning the work contents, working procedures, points concerning industrial accident prevention, etc., for the day.
- Announcing the results of liaison and coordination arrangements between work assignments.
- Understanding the views and opinions of related workers in the prevention of industrial accidents.
- Safety activities such as hazard prediction activities

In a report on “Benchmarking Study on Construction Safety in Japan”, in the July 2001 issue of “*Green Cross*” published by the Hong Kong Occupational Safety and Health Council, it was suggested that –

“The Safe Working Cycle (SWC) has become a corner stone of the Japanese construction industry consisting of commencing a working day with 20 minutes of exercises (for all site staff), an introduction to the day’s activities and their inherent risks, an introduction to new workers and an impressive display of team spirit.

The SWC continues throughout the day with the prediction of hazardous activities and pre-commencement inspections being given particular attention. The Project Manager will lead safety patrols, safety co-ordination meetings and after work site clean up being a normal, not exceptional, daily routine.”

The HKSAR Government’s Trade and Industry Department has funded a development project named “5-S”. The 5-S practice is designed to establish and maintain quality environment, and people have to be trained as the ‘5-S’ Lead Auditors to ensure implementation.

The Environment, Transport and Works Bureau adopts a similar system “Site Safety Cycle” aiming at promoting safety and housekeeping of construction sites.





The Housing Department adopts a system called “Building Pass” which also encompasses similar activities in its “Safety Assessment”. The Safety Assessment is composed of four factors:

- HASAS Score for Safety & Health Management System
- HASAS Score for Implementation of the Safety & Health Plan
- General Site Safety
- Block Related Safety

The Housing Society adopts a system called “5-S management system” and the 5-S Association accredits it with the 5-S Certification. A 5-S Charter is signed between the Society and its main contractors to ensure smooth implementation.

Worksite cleanliness



Dirt and mud clearing





Road surface cleaning



Construction wastes cleared from safety nets

Safety net cleared of wastes to prevent over-loading the scaffold



Cleansing of all incoming vehicles

Water jet to clean wheels





Perimeter of worksite just outside the fencing also cleansed



Hoarding just behind the site office

Temporary store for bamboos



Proper stacking of metal scaffold parts





Well organized stacking of pipes to prevent slippage



Workers learning the proper method of cleaning concrete dirt



Regular spraying to prevent mosquito breeding





Front line supervisors also joined in the exercise



Workers from subcontractors during morning exercise



Morning exercise





Morning exercise



Morning exercise



Work allocations recorded on the notice board





Workers attentively waiting for details of work allocation



Sub-group briefing on the details of the work distributed



Final checking of equipment before work





Checking and recording of work done



Checking and recording of work in progress



Final briefing on the use of PPE





Workers to ensure that PPE is properly worn against a mirror and a dummy



Mirror for use by workers.

Safe Working Cycle banners displayed in prominent position





CHAPTER 3

Controlling Risks



To control risks in construction work is a complex task. It is often under-estimated and simply treated as common sense. In order to address the problem effectively, the Health and Safety Executive, U.K. suggests a 5-step approach:

- STEP 1: Look for the hazards,
- STEP 2: Decide who might be harmed and how,
- STEP 3: Evaluate the risks and decide whether the existing precautions are adequate or whether more should be done,
- STEP 4: Record your findings, and
- STEP 5: Review your assessment and revise it if necessary.

The HSE also publishes a practical guide: ‘*Successful health and safety management*’, for directors, managers, health and safety professionals and employee representatives who want to improve health and safety in their organizations. It outlines the principles and management practices which provide the basis of effective health and safety management; sets out the issues which need to be addressed, and can be used for developing improvement programmes, self audit and self assessment as summarized below –

POLICY	Workforce involvement in development or review of policy statement
<p>ORGANISING</p> <ul style="list-style-type: none"> ▪ control ▪ communication ▪ competence ▪ co-operation 	<p>Giving employees specific health & safety responsibilities.</p> <p>Employee involvement in delivering health and safety messages</p> <p>Employee involvement in delivery and design of training</p> <p>Structure of Safety Committees Suggestion Schemes</p>





<p>PLANNING</p> <ul style="list-style-type: none"> ▪ objectives/plans ▪ risk assessments ▪ procurement ▪ design ▪ problem solving ▪ operation of risk control systems ▪ 	<p>Employee involvement in setting health and safety plans and objectives Employee involvement in risk assessments Employee involvement in the procurement of equipment and materials Employee involvement in the design of new ways of working Employee involvement in problem solving Employee involvement in planning risk control systems</p>
<p>MEASUREMENT</p> <ul style="list-style-type: none"> ▪ active monitoring ▪ reactive monitoring 	<p>Employee involvement in carrying out inspections, observations etc. Employee involvement in accident and near miss investigations and hazard spotting</p>
<p>AUDIT & REVIEW</p>	<p>Employee involvement in audits of the efficiency, effectiveness and reliability of the H&S system and in the systematic review of performance based on data from monitoring and audits.</p>

Electricity safety

Workers engaged in construction work are frequently exposed to electric currents in various forms from overhead cables, underground supply lines, to electrical installations and tools. In fact, they are exposed to electrical energy in their daily work. Shocks and electrocutions can occur to workers engaged in different types of jobs.

Many workers are unaware of the potential electrical hazards present in their work environment, which makes them even more vulnerable to the danger of electrocution. Others are being too ignorant to believe that electrocution is only too remote because very often they only receive minor electric shock or burns from arcing and flashover.

Many of these workers are experienced electricians. They customarily take short-cuts by working on live apparatus without rendering the circuit dead or awaiting a permit to work in order to save time.





Electrical injuries in worksites consist of four main types:

- Electrocution (fatal)
- Electric shock
- Burns
- Falls caused by contact with electric current

General precautions

- Prohibit work on new and existing live circuits until all power is shut off and a positive permit to work system is in place.
- Do not use worn electrical cords or cables.
- Use only 3-wire type extension cords.
- Maintain all electrical tools and equipment in safe condition and check regularly for defects.
- Remove broken or damaged tools and equipment from the jobsite.
- Protect all temporary power (including extension cords) with circuit protection device.
- Do not bypass any protection system or device designed to protect employees from contact with electrical current.
- Locate and identify overhead electrical power lines. Make sure that ladders, scaffolds, equipment or materials never come into close proximity of electrical power lines.

Control electrical hazards through safe work practices.

Plan your work and plan for safety.

- Avoid wet working conditions and other dangers.
- Avoid overhead power cables.
- Use proper wiring and connectors.
- Use and maintain tools properly.
- Wear suitable personal protective equipment.

Control contact with electrical voltages and control electrical currents to create a safe work environment.

- Prepare a permit-to-work system.
- Prevent overloading by using the right type of wiring.
- Prevent exposure to live electrical parts by isolation or rendering the circuit dead.
- Prevent exposure to live wirings and parts by using insulation.
- Prevent shocks by suitable earthing .





- Prevent shocks by using suitable earth leakage detection device.
- Prevent overloading by using overcurrent protection device.

To prevent injuries and deaths of workers working with hazardous electrical energy in worksites:

- Develop and implement a safe system of work.
- Identify and display suitable warning signs.
- De-energize, isolate, block, and/or release all forms of hazardous electrical energy before work begins.
- Plan and implement a permit-to-work system.
- Require that each lock used to secure an energy control device be clearly labeled with durable tags to identify the worker assigned to the lock.
- Make sure that the worker who installs a lock is the one who removes it after all work has been completed.
- If work is not completed when the shift changes, workers arriving on shift should apply their locks before departing workers remove their locks.
- Verify by test and/or observation that all energy sources are de-energized before work begins.
- Inspect repair work before reactivating the equipment.
- Make sure that all workers are clear of danger points before re-energizing the system
- Train all workers in the basic concepts of electrical safety.
- Establish a control program with all entry to confined space.

Common electrical hazards in construction worksites:

Plants and materials frequently come into contact with electrical transmission lines or cables:

- Derricks and cranes
- Excavators
- Projected metal building materials
- Metal ladders
- Scaffolds





To avoid the chance of injuries:

- Look for overhead and buried transmission lines or cables
- Post suitable warning signs
- Contact power utility company for buried transmission cable locations and keep a safe distance away.
- Until verified and rendered dead, assume that all overhead transmission cables are live.
- Use non-conductive ladders when working near power transmission lines.
- Provide suitable training and information to plants operators and workers.

Lack of ground fault protection

Due to the dynamic, rugged nature of construction work, normal use of electrical equipment at worksites can quickly cause wear and tear that results in insulation breakdown, short-circuits and exposed wires. If there is no leakage protection, these can cause a short circuit that send current through the worker's body, resulting in electric burns, explosions, fire, or death.

To avoid the chance of injuries:

- Use leakage protection circuit breakers.
- Follow manufacturer's recommended testing procedure to ensure circuit breakers are working correctly.
- Use double insulated tools and equipment with clear and distinctive markings.
- Use tools and equipment according to the manufacturers' instructions.
- Visually inspect all electrical equipment before use.
- Remove from service any equipment with frayed cords, missing ground prongs, cracked tool casings, etc.
- Apply a warning tag to any defective tool and do not use it until the problem has been corrected.





Improper use of equipment

If electrical equipment is used in ways for which it is not designed, you can no longer depend on the safety features built in by the manufacturer. This may damage your equipment and cause employee injuries.

To avoid the chance of injuries:

- Use only equipment that is approved.
- Use all equipment according to the manufacturer's instructions.
- Do not modify cords or use them incorrectly.

Improper use of extension and flexible cords

The normal wear and tear on extension and flexible cords at your site can loosen or expose wires, creating hazardous conditions. Cords that are not three-wire type, not designed for heavy-duty-usage, or that have been modified, will increase the risk of contacting electrical current.

To avoid the chance of injuries:

- Use factory-assembled cord sets.
- Use only extension cords that are three-wire type.
- Use only extension cords that are designated for the purpose of use, e.g. weather proof, flameproof, etc.
- Provide proper training in handling cords and advise workers never pull the plugs from receptacles by the cords.
- Check all cords on-site before use. Report any cords where signs of wear and tear or makeshift modifications on any parts are found. Take away all such cords from service immediately





Use of two-pin plug and extension cord/socket



Socket board not well placed



Electric wiring on wet floor





Weather-proof sockets suitable for damp environment



Proper management of cabling



Secured switchbox





Hand tools

Hand tools and more commonly nowadays, powered tools, are widely used in worksites. However, the standard of tool selection, maintenance, training and work practices vary widely. Injuries and even fatality occur especially when workers or electricians are not working with a suitable safe system of work. Furthermore, accidents often occur when the fundamental precautions are neglected:

General precautions

- Unsafe hand tools should not be used.
- Impact tools, such as drift pins, wedges, and chisels, should be kept free of mushroomed heads.
- The wooden handles of tools should be kept free of splinters or cracks and should be kept tight and fit in the tool
- Electric power operated tools should either be of the approved double-insulated type and clearly labeled or properly grounded using approved three-wire cord having the ground wire permanently connected to the tool frame as a means for grounding the other end
- All hydraulic or tools which are used on or around live power lines or equipment should be equipped with suitable non-conducting hoses and properly maintained





Before commencement of work on each work shift, conduct a risk assessment, if required:

- No broken plugs, sockets, switches, defective leads.
- Start and stop switches clearly identified and switchboards secured.
- All power tools are in good condition.
- Suitable earth leakage systems installed and tested.
- Tools and leads inspected and clearly marked and no cable or wiring tripping hazards.
- Switches/circuits clearly identified.
- No work near exposed live electrical equipment.
- Permit to work system in place, especially when working in hazardous locations.
- Provide appropriate fire fighting equipment.

- If situation warrants, consider the use of lower operating voltage during the planning stage.





Protective equipment and precaution:

- Shielded or insulated tool and equipment should be used.
- Rubber insulating gloves.
- Rubber matting for use around electric apparatus.
- Rubber insulating blankets.
- Rubber insulating hoods.
- Rubber insulating line hose.
- Rubber insulating sleeves.
- Rubber protective equipment should be visually inspected prior to use.
- Protective equipment of material other than rubber shall provide equal or better electrical and mechanical protection.
- Protective hats should be worn at the jobsite by employees who are exposed to the hazards of falling objects, electric shock, or burns.
- Personal climbing equipment.
- Safety harness with straps or lanyards, pole-belts, etc. should be worn to protect employees working at elevated locations on poles, towers, or other structures except where such use creates a greater hazard to the safety of the employees, in which case other safeguards should be employed.
- Safety harness and safety straps shall meet the required standards, and be free from additional metal hooks.
- Body belts and straps should be inspected before use each day to determine that they are in safe working condition.
- Lifelines and lanyards should comply with the required standards.





Clean and well maintained tools



Noise control

Most construction workers are exposed to excessive construction noise. One can get tinnitus, a ringing sound in the ears, or a temporary loss of hearing. Exposure to longer period can cause tiredness and nervousness.

Many people working in the construction industry treat noise as something innocuous and inherent in the trade. Since most hearing loss happens gradually, the impact is often neglected. But if hearing is lost, even temporarily, it may create danger to the workers immediately.

Exposure Levels

Noise levels are measured in decibels (dBA). Since decibels are on a log scale, 73 decibels is 2 times as loud as 70 where hearing protection aid is required. In general, protection is required when workers are exposed to a noise level exceeding:

- 8 hours at 90 decibels
- 4 hours at 95 decibels
- 1 hour at 105 decibels

When the noise is 95 decibels, one may work with no hearing protection for only 4 hours. Even so, this noise level is not safe; 1 in 5 people exposed regularly to 90 decibels will lose some hearing. Short, very loud (impact) noises can do the most harm.





Sources of noise

Most construction noise comes from equipment. The decibel levels of machines may require attention. These need to be measured and monitored:

- Pile drivers
- Sheet pile extractors (percussion-type)
- Pneumatic hammer
- Earth breakers
- Jackhammer
- Crane
- Concrete, marble tiles, glass cutter and polishers
- Hammer
- Portable saw
- Earthmover
- Front-end loader
- Bulldozer
- Backhoe

The noise level varies with the same piece of machine or plant. For example, the noise from an earthmover may be 94 decibels from 10 feet away. The noise is only 82 decibels if you are 70 feet away. A crane lifting a load can make 96 decibels of noise; whereas at rest, it may make less than 80 decibels.

Steps for hearing protection:

- Make the workplace quieter
- Procure quieter models in equipment selection
- Good maintenance for existing equipment.
- Locate noisy plant and equipment, like compressors and generators, as far away from the work zone as possible.
- Simple shielding around noisy equipment often makes a lot of difference.

Reduce exposure

Job rotation, if possible, after all engineering methods are exhausted and if the noise level is still unacceptable. Take rest breaks away from the noisy area at suitable intervals.





Protect by personal protective equipment

If noise reduction measures cannot reduce the noise level to a desired level or not low enough, wear hearing protection. Most hearing protection is easy to put on or take off. Training on the use and selection of a suitable protective gear is important.

Information and Training

- Measure noise level at regular intervals and put up suitable warning notices and signs.
- Identify noise areas and declare them as noise protection zone.
- Provide suitable protectors when workers are required to listening to human voices, signals, warnings or backup alarms. Suitable type of protectors can effectively screen out unwanted noise to suit individual needs.

Noise barrier for earthwork



Circular cutter with noise barrier





Specially designed crusher for better noise protection



Specially designed equipment for noise protection



Sound barrier for drilling





Disposal of building debris/waste/rubbish

Disposal of building debris, waste and rubbish in building construction worksites, if properly managed, can save a lot of workers' lives and prevent unnecessary injuries.

Main cause of injuries

- Manual handling injuries
- Cuts from sharps
- Slips and trips
- Struck by objects (e.g. tipping of rubbish, fallen building materials caused by poor housekeeping)
- Fall from height (e.g. rubbish clearing in lift shafts)

Fire caused by rubbish

Rubbish burning on worksites or cigarette butts left by workers igniting combustible waste on site could cause fire.

Scrap wood or chips, saw dust waste, and paper bags or cartons should be removed from the immediate work area as the work progresses.

All solvent waste, oily rags, and flammable liquids should be kept in fire resistant covered containers until they are removed from the worksite.

When materials are to be dropped from any point lying outside the exterior walls of the building

- an enclosed chute of sound material, preferably metal or other non-combustible materials should be used.
- the enclosed chute should be a slide, totally enclosed on all sides and with adequate diameter, through which materials can be moved from a high place to a low one
- if disposal is required at intermediate floor levels, openings with secured gates should be fitted
- warning signs should be posted at prominent places

When debris is dropped through holes onto the floor without the use of chutes

- the area onto which the material is dropped should be completely enclosed
- erect barricades of adequate height and set back from the projected edge of the opening above
- warning signs about the hazard of falling materials should be posted at each level
- removal should not be permitted in the lower area until debris handling has ceased from above.





Safe access

In providing a safe place of work, one must not overlook the importance of providing and maintaining safe access to and egress from the workplaces. Very often, risk assessment is critical during the planning stage with all the details put down in a method statement.

Unsafe access contributes to many of the more serious accidents in worksites. The major reasons are: most of the access and egress is transient in nature, rapid change in the site condition; multiple use by different contractors; a high turnover and insufficient briefing and training of the workforce.

- In general, a contractor should
- provide stairways, ladders, ramps, or other safe means of egress to workplaces such as working platforms
 - position the means of egress within a reasonable distance from workers
 - use structural ramps solely for access or egress from excavations designed by a competent person
 - ensure that when two or more components form a ramp or runway, they must be connected to prevent displacement
 - attach cleats or other means of connecting runway components in a way that would not cause tripping

Design for safe access

The contractor should provide

- adequate information for use by persons to access
- ramp and platforms of adequate width and with guard rails where practicable
- mobile plants such as hydraulic platforms or cherry pickers when permanent access and egress are not practicable
- a risk assessment to determine whether rope access or other means are practicable when all intrinsically safe methods required by legislation are exhausted





Use of personal protective equipment

The use of personal protective equipment (PPE) is to combat exposure to hazards when engineering and/or administrative controls are not feasible or effective in reducing these exposures to acceptable levels. It is important to eliminate all workers' exposures to hazards in their worksites and to determine if PPE should be used to protect them.

Personal protective equipment must only be used as a last resort. It is not a substitute for taking safety measures. A well planned site layout and process control can often eliminate most hazards on worksites.

If PPE is to be used, a PPE programme should be introduced and maintained. This programme should contain identification and evaluation of hazards in the workplace. If the use of PPE is an appropriate control measure, the programme should cover: how it is selected, maintained; and how its use is evaluated; training of employees using the PPE; and vigilance of the programme to determine its effectiveness in preventing workers from injury or illness.

Head protection

- Workers must wear safety helmets when overhead, falling, or flying hazards exist
- Inspect safety helmets routinely for dents, cracks, or deterioration.
- If a safety helmet has been hit by a heavy blow or electrical shock, you must replace it even when you are unable to detect any visible damage.
- Maintain safety helmets in good condition; do not drill; clean with strong detergents or solvents; paint; or store them in extreme temperatures.

Eye and face protection

- Workers must wear safety glasses, goggles or face shields for welding, cutting, nailing (including pneumatic), or when working with concrete and/or harmful chemicals.
- Eye and face protectors are designed for particular hazards. They should be selected to match the hazard.
- Replace poorly fitted or damaged safety glasses.





Foot protection

- Safety shoes or boots should be slip-resistant and have puncture-resistant soles (to prevent slipping and puncture wounds).
- Toe-cap is recommended to prevent crushed toes when working with heavy rolling equipment or falling objects.

Hand protection

- High quality and of suitable material gloves can prevent injury.
- Glove size should fit the workers.
- Wear the right gloves for the job such as heavy-duty rubber for concrete work, and welding gloves for welding.

Others

- Special personal protection in handling hazardous solvents and chemicals, asbestos, etc. working near or over water, in confined spaces or workplaces affected by gas, fumes, dust, etc.

Proper PPE





Welding screen

Barrier screen constructed of non-combustible material

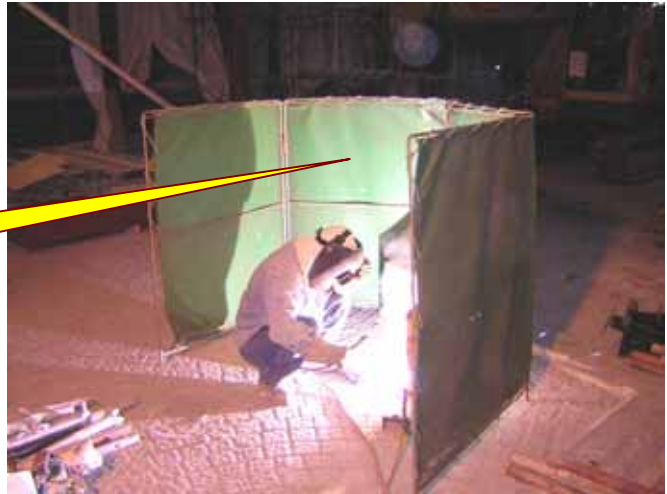

Proper PPE



Proper PPE





CHAPTER 4

Foundation Work



Foundation work often involves massive operations in earthwork such as excavation or digging large holes in the ground, or where the face of the earth, rock, sand, soil or other materials is removed.

Typical examples are:

- a trench, ditch, shaft well, tunnel, pier hole, cutting, caisson or cofferdam
- a hole drilled into the earth

Cave-ins are the most feared hazard in earthwork like excavation and trench work. But other potentially fatal hazards exist, including asphyxiation due to the lack of oxygen in a confined space, inhalation of toxic fumes, drowning, etc. Electrocutation or explosions can occur when workers are in contact with exposed underground utilities.

Caisson

For many years, hand-dug caissons had gone through a disturbing history of high accident rate and health hazards. The Building Authority in 1995 banned the use of hand-dug caissons mainly to minimize workers from:

- being struck by an object falling into the excavation
- being trapped by the collapse of an excavation (all depths)
- falling into the excavation
- asphyxiations, inhaling, or otherwise being exposed to, carbon monoxide or other impurities in the air in the vicinity of the excavation
- drowning/burying when overcome by sudden in-flush of water
- other hazards including noise, silica dust, explosive or flammable gases, such as methane





Exemption may be granted only if an architect or structural engineer can demonstrate to the satisfaction of the Building Authority that the following circumstances exist:

- the depth of the hand-dug caisson does not exceed 3 metres and the diameter of the inscribed circle of the hand-dug caisson is not less than 1.5 metres; or
- for the site concerned:
 - the use of a hand-dug caisson is the only practical construction method; or
 - there is no other safe engineering alternative.

Examples of these are: narrow or steep sloping sites where difficult access or insufficient working space makes it not possible or not safe to use machine tools.

In these exceptional circumstances, the authorized person/registered structural engineer must specify stringent safety requirements in the method statement for the building works and ensure that the registered contractor is fully aware of and complies with all safety requirements. In this respect, the provisions of the Construction Site (Safety) Regulations administered by the Commissioner for Labour should be observed.

In all caisson operations, including complex foundation work, a risk assessment should always be conducted in the early planning stages.

Risk assessment

- Assess the risks that may result because of the hazards
- Decide on control measures to prevent or minimize the level of the risks
- Implement the control measures
- Monitor and review the effectiveness of the control measures

Person being trapped by the collapse of an excavation (all depths)

- do as much work as possible from outside the excavation
- backfill excavation as soon as possible
- batter, bench or shore sides of excavation
- place excavated materials, equipment and other materials at a distance from the edge of the excavation so that the force exerted on the edge of the excavation does not lead to the collapse of the excavation
- limit the approach of vehicles and plant by erecting a barrier, such as a wheel buffer





Person being trapped by the collapse of a trench more than 1.5 m deep

- shore all sides of the trench; or
- bench all sides of the trench; or
- batter all sides of the trench; or
- obtain written approval from a geotechnical engineer that all sides of the trench are safe from collapse; or
- use a combination of the above measures

Person being struck by an object falling into the excavation

- do not lift or suspend loads over any person working in the excavation
- use excavators and cranes with controlled descent valves on the hydraulics fitted to the boom or dipper arm to prevent the boom or load from falling onto the workers in the event of hydraulic hose failure
- evict persons from the excavation when lifting and placing loads in the excavation
- use plant fitted with suitable overhead protection to protect against falling objects
- erect barrier along the edge of the excavation to prevent objects falling into the excavation
- use wheel buffers

Person falling into the excavation

- backfill excavation as soon as possible
- secure a cover over the excavation
- provide safe access to and from the excavation

Person inhaling, or otherwise being exposed to, carbon monoxide or another impurity of the air in the excavation

- as part of the risk assessment process - determine the likelihood of airborne and soil contaminants being present and the need to undertake formal air monitoring in the excavation
- implement control measures necessary for entering and working in a confined space
- do not expose persons to a hazardous substance at a level exceeding the international exposure standard for that substance
- monitor the level of any airborne contaminant in the excavation
- monitor for explosive gases or vapours
- ensure there is adequate ventilation provided to the excavation





- use extractor fans to remove airborne contaminants and explosive gases from the excavation
- position vehicles, plant and machinery away from the excavation
- provide and use appropriate personal protective equipment, such as respiratory equipment, protective clothing, safety gloves
- remove all sources of ignition if explosive gases are present.

Sheet piling

Sheet piles are commonly used to support excavations in foundation work. Traditionally, these operations are performed without proper planning especially during the pre-work stage. Training and information provided to workers also vary in standards. Sheet piling in the past had a poor record of high accidents, often resulted in fatality.



The cause of fatal accidents pertaining to sheet piling was due to one or a combination of the following failures in ensuring:

- adequate depth for interlock of sheet piles or the correct penetration depth.
- deviations and leaning (transverse or longitudinal) of sheet piles within tolerance limit.





It is common in the piling industry to use a cage to lift workers, also called “top man” or “pile monkey”, onto the top of sheet piles to carry out the aligning or interlocking by hand. This working process by alternative methods by some contractors can avoid such hazards.

Depending on the nature of work and site conditions, two alternative methods have been introduced by using:

- threaders and shackle release device
- sheet pile trestle

The crane is lifting the sheet pile, interlocking manually in an exposed dangerous position by the topman



Workers working at the top of the pile and on the horizontal guide beam





Workers staying on top frame level can be hit or trapped in between



Threaders and shackle release device:

Proprietary systems used elsewhere have been imported to offer a safer alternative to this particular process. Some contractors are also beginning to use local-made models to cut cost. The basic principle of these proprietary systems is to use a pile-threader and a shackle release device. All the necessary operating procedures can be done on the ground.

The sheet pile threader is designed for safe and rapid sheet pile interlocking when sheet piles are being pitched in panels. It replaces the “top man” or “pile monkey” who normally carries out the interlocking by hand.

The basic method of operation using a universal pile treader is as follows:



The threader is pre-loaded by pulling the pull wires and vice block against spring pressure and cocking.

The pile to be pitched is lifted until the bottom is at about 1m (3ft) above ground level. The threader is then clamped onto the pile with the vice. The relative position of the pile is governed by a stop plate to suit the pile section being used.





With the threader attached, the pile is then lifted by the crane to the end-pile of the panel. By means of the rollers, the lower part of the threader is then clamped to the last pile in the panel so that the interlocks are adjacent to each other. The clamping operation is designed to permit free movement of the pile and the threader in a vertical direction but prevent movement in any other direction. This attachment is normally done at top frame level. The cocking device inside the vice slide tubes is then released.

The crane lifts the pile to be pitched until its bottom edge is above the previous pile in the panel. The spring pressure on the vice block forces the pile across into the interlocking position. As the pile is lowered, it interlocks. The threader is then unclamped at top frame level.

Ground release shackle device

The use of these shackles complements the “feet on the ground” approach to piling. When used in conjunction with the sheet pile threader, there is no need for site operatives to go above the safety of top frame level for interlocking sheet piles or releasing the lifting shackles



Ratchet release shackles

The ‘shackle release’ is used for lifting steel piles from ground level to some safe vertical position at any height. It enables these steel elements to be subsequently disconnected safely and efficiently from a remote location. For pitching steel sheet piles, a sheet pile threader is used for automatic remote interlocking of adjacent sheets





Another method using a Universal Sheet Pile Threader:

This threader that comes in two pieces can be manhandled and readily operated by typical site personnel. The unit can be adjusted to suit whatever pile section is being used on the job site without the need for additional items. The standard threader requires a different set of guide Rollers for each pile section. When threading single piles, the threader will readily switch from threading on the left hand to the right hand, thanks to its unique two-piece design. This means that only one unit is required on the job site. The threader requires two units for fast threading of single sheet piles – one set to the left and the other to the right.

Universal Sheet Pile Threader

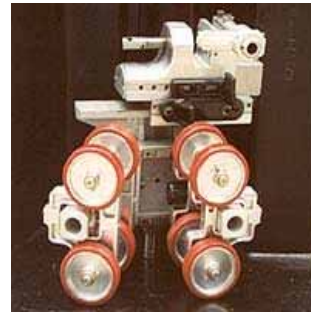

The unit is adjusted to suit the particular pile section being threaded



A different type of threader





Another method using a guide frame fixed with suitable platforms for workers at intermediate levels

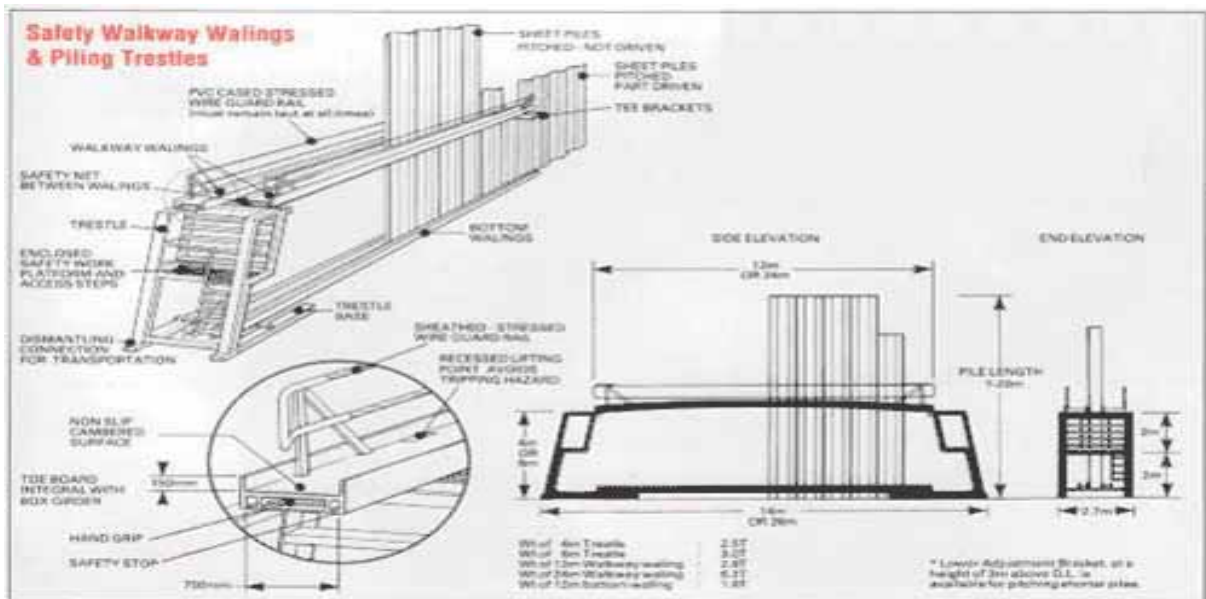

In the past, there had been accidents involving workers falling from the man-cage. The man-cage had to be lifted up by cranes and attached onto the top of the sheet piles. When the hooking device of the man-cage failed, the worker fell to the ground together with the cage. Another case involved a crane. When lifting the loaded man-cage, the cage fell during the journey, resulting in fatal injury of workers. The safety walkway above provides a safe place of work for workers.

Accidents also occurred in the past when sheet piles are being extracted, which is rather common locally, after the excavation work is over. Common errors are: buckling of the jib of the crane or/and overturning of the crane. In fact, tipping of the crane is





also a very common scene. This situation happens from time to time, causing repeated overloading of the crane and increasing the chance of overturning.

Advantages of employing a threader:

- The sheet pile threader replaces the dangerous, manual operation performed by a top man climbing or being hoisted up to the top of the piles and interlocking the piles.
- Interlocking piles with the pile threader is faster than any other safe method of working.
- The sheet pile threader makes it possible for piling work to be done under more severe weather conditions as interlocking can take place even under high winds.

Safe sheet piling operation depends on good working conditions. The health and safety arrangements should be periodically inspected and maintained:

- Safe storage and handling of sheet piles, struts, king piles, bracing beams and walers.
- Proper handling and maintenance of piling hammer/extractor.
- Boring machines are in working condition if pre-boring is required.
- Lifting cranes are of sufficient capacity, and boom length and bearing capacity check to ensure safety.
- Proper means of transport for excavated materials (No excavated materials are to be placed near to the pit), as this will affect the well-planned sheet pile wall operation.
- Pumps are in good working condition.
- All welding and cutting equipment are in good working order, with proper PPE in use and the workers involved suitably trained.

The Labour Department has published a guide “*Safety Guide for Interlocking of Steel Sheet Piles*” giving details of the hazards in using man-cage and the appropriate measures to be taken.

Shoring

Shoring uses structures such as a metal hydraulic, mechanical or timber shoring system that supports the sides of an excavation. It is designed to prevent cave-ins. In fact, sheet piles are also a form of shoring.

After the excavations are completed, take special precautions to prevent injury from





cave-ins in the area between the excavation wall and the foundation wall:

- Protect the depth of excavation against cave-ins.
- Keep the horizontal width of the excavation to make sure that work activity would not vibrate the soil while workers are in the trench.
- Plan the foundation work to minimize the number of workers in the trench and the length of time they spend there.
- Inspect the trench regularly for changes in the stability of the earth (water, cracks, vibrations, spoils pile).
- Stop work if any potential for cave-in develops and fix the problem before work starts again.

For safe trench excavation, adequate support must be installed ahead of excavation as far as is practicable.



The Labour Department stipulates the health and safety requirement in Regulation 39(1) of the Construction Sites (Safety) Regulations that states

“The contractor responsible for any construction site at which excavating or earthworking operations are being carried on shall cause a structure made of suitable timber or other suitable material to be erected in connection with the operations as soon as may be necessary after their commencement so as to prevent workmen employed on the site from being endangered by a fall or displacement of earth, rock, or other material (including waste material and debris) adjacent to or forming the side of the excavation or earthwork.”

Specific design with details of shoring complete with drawings should be prepared for excavations with particular attention to:

- the depth of the excavation, and
- possible effects affecting roads, buildings, structures, slopes, services of adjoining areas, from the base of the excavation to the ground surface, and





should be carried out by a professionally qualified engineer who is competent in carrying out a proper shoring design.

General precaution for safe excavations

- Shoring in place and in sound condition
- Excavation well secured
- Signage displayed
- Banks battered correctly and spoiled away from edge
- Clear and safe access around excavation
- Separate access and egress points from excavation
- Safe work procedure in place

Points to discuss at the initial planning meeting:

- Find the location of all underground utilities by contacting the local utility companies to identify and locate the services before digging.
- Keep workers away from digging equipment and never allow workers in an excavation when equipment is in use.
- Keep workers away from space between equipment in use and other obstacles and machinery that can cause crushing hazards.
- Keep equipment and the excavated dirt (spoils pile) back 2 feet from the edge of the excavation
- Have a competent person conduct daily inspections and correct any hazards before workers enter a trench or excavation.
- Provide workers with a way to get into and out of a trench or excavation such as ladders and ramps. They must be within a reasonable distance from the workers.
- For deeper excavations and utility trenches, use shoring, shields (trench boxes), benching, or slope back the sides. Refer to the result of soil analysis to determine the earth's safe slope angle.
- Keep water out of trenches with a pump or drainage system, and inspect the area for soil movement and potential cave-ins.
- Keep drivers in the cab and workers away from dump trucks when dirt and other debris are being loaded into them.
- Don't allow workers stay under any load and train them to stay clear of the back of vehicles.

The statutory requirements on the use of excavators in construction work are clearly laid down in the 'Code of Practice - Safe Use of Excavators' issued by the Commissioner for Labour. It covers details on the safe use and operation of excavators for excavation and earth moving operations, including the safe use of





bucket attachments.

Lightweight aluminum shoring for smaller trenches.



Flimsy trench protection



Custom-sized shoring system as timber mounted.





Man-hole boxes with steel panels



Screw jacks with steel shoring plates



Screw jacks using timber battens and steel panels





Custom-sized shoring with steel panel mount



Access/egress

Proper planning of access and egress, including rescue in case of emergency, is very important. Access to the surface should be by means of:

- ladders;
- stairways; or
- ramps.

In trenches, access ladders should be spread out at intervals and at locations workers are working and near the trench.

Normal access routes used within an excavation should, whenever practicable, permit workers to pass along without bumping into obstructions or being hit by debris. Walking in an excavation should be made possible by secure footing without risk of falling.

In situations where an excavation or trench is heavily timbered and where headroom is limited, access to and from work should be along well-defined routes which can be protected more readily and the use of other routes should not be permitted.

Separation of traffic

Wherever practicable, the route used to bring out excavated material should be separated from that used by the workers. In a small shaft or drive where it is not possible to provide separate routes for the two kinds of traffic, the movement of workers should be forbidden while excavated material or plant is being moved and vice versa.





In shafts shallow enough for workers on top to see and talk to the workers below, no difficulty should arise, but in shafts of intermediate depth, in which the workers have to climb up and down the ladders, there is need for an effective signaling system and there may be a requirement for automatic locking of winding gear while workers are moving.

Where mechanical haulage is used in small drives, manholes or refuges should be excavated into the side of the drive to provide shelter from passing traffic. Such refuges should be of a reasonable size and appropriately spaced on the same side of the drive.

Secure footing

This is essential for safe access. Loose stones and large rock projections should be removed and in some cases it may be necessary to provide a timbered walkway to ensure safe walking. Accumulations of mud should be prevented and sloping walkways should be cleared or otherwise made slip-proof.

Adequate lighting

Where daylight is insufficient shafts, drives, trenches and open excavation should be provided with adequate lighting. Glare should be guarded against because contrasted with a deficiency of light, it increases considerably the risk of falls from slipping or tripping.

Protection from falls

Where there is a risk of any person falling from an access way, a handrail, and sometimes an intermediate rail or a toe board, should be provided to enable persons to pass more easily and to prevent falls. At any landing, the ladder below should be offset from the ladder above so that it is not possible for a person or articles to fall past the landing. Landing platforms should be fitted with guard rails and toeboards.





Emergency access and egress

When an emergency occurs, only rescue traffic is to be permitted in the area and all access ways cleared immediately. Operators must always park their vehicles clear of access routes (haul roads) to leave adequate clearance for emergency traffic. Rescue teams will then be able to use routes normally used by plant. Rescue traffic may well include stretchers and this should be allowed for when planning details of the access throughout the job.

Whenever possible, some alternative access should be provided for emergency use. For example, any open excavation should have a loose ladder handy at the top which should be left in a place known to all workers and reserved solely for emergency use.

Emergency access also implies safe egress from the face of an advancing excavation. At the face, while supporting timber is being placed, protection cannot be as good as where the supporting work is completed. This zone of reduced protection should be kept short by keeping the support as close as practicable to the face being excavated.

Workers should be provided with a clear run to safety should there be a fall of earth. This requires the floor of the excavation to be kept clear as possible of loose spoil, tools, timber, etc. Full walking headroom should be provided when practicable in a trench near the working face. All workers and supervisory staff should try to keep the floor clear of hazards. The provision of sufficient headroom for safety near the face will often prove difficult, and therefore should receive special attention.

Ramps and runways

Ramps or runways used for running plant into and out of an excavation must be constructed of appropriate strength, width and grade for the plant being used. Ramps intended for use by track vehicles only should be so marked, and no other vehicles should be allowed to use them. Frequent careful examination and maintenance is needed to keep ramps in a safe and serviceable condition.





Ladders

Ladders are commonly used as a means of access into and exit from an excavation and should extend at well above the top of the excavation. Properly made access cuts are also acceptable.

Scaffolding

Scaffolding may be required for any special excavation work.

Ventilation

Fumes from petrol or diesel driven machines are a hazard in an excavation. Portable petrol or diesel engines should not be permitted to operate within an enclosed area e.g. trench support systems or well liners, etc.

Additional precautionary measures

Where trenching work is at a remote location, an effective means of communication such as a telephone or walkie-talkie should be available to call for advice or for help in emergencies.

In all cases, if there is any uncertainty about the minimum amount of safe trenching support, it is better to play safe and:

- batter the excavation
- over-design the support or
- obtain competent professional advice.

Plant and excavator at the bottom of excavation





Workers at the bottom excavation cleared of overhead activities



Plant and vehicle at the upper deck of the excavation



Enclosed stairway for safe access and egress





Workers at the bottom of excavation (with temporary walkway and latrine facilities)



Workers' quarters and temporary material storage platform at intermediate levels below the excavation



Upper deck built for excavator and loader for clearing mud





Workers erecting ladder access/egress and decking for landing



Staircase protected by net reaching down to the bottom of the excavation



Excavation in progress at the formation level of the 61m diameter cofferdam (IFC I)





The 61m diameter cofferdam formed by 1.5 m thick diaphragm wall panels was strengthened by RC ring beams

Supporting plants at the edge of the excavation

Enclosed access and egress.



Close-up view of the column close to ground level

Temporary barrier at the edge.



The core wall ascending from the raft at the bottom of the cofferdam

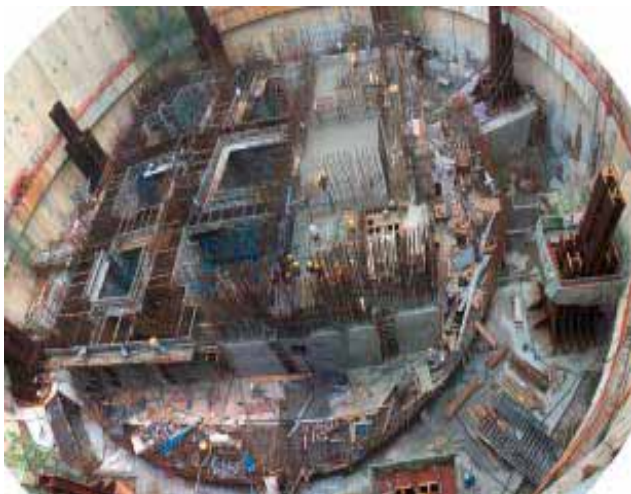



The cofferdam with the core wall and columns in position to the ground level

Enclosed stairs for access and egress



Used formwork with nails placed around the podium blocking access and egress

Planks with protruding nails

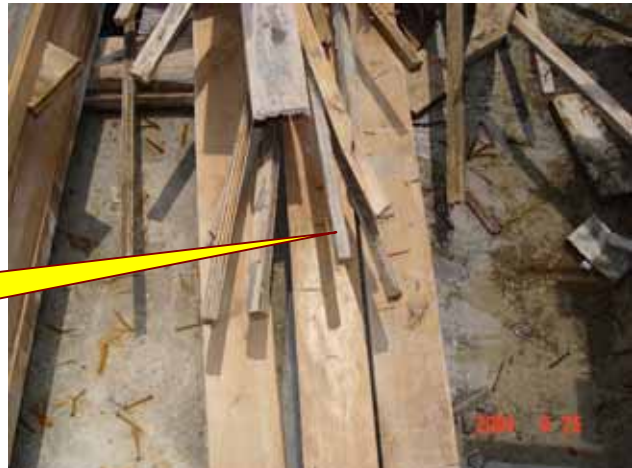

Poor organization leaving no proper passageway for access and egress





Passageway substandard leaving safe access and egress almost impossible

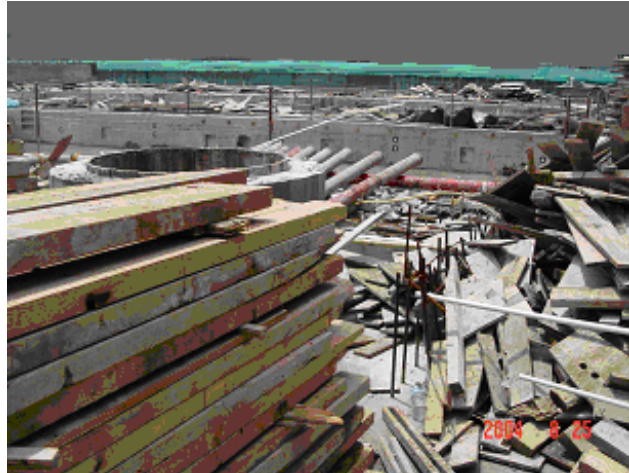

Passageway also blocked rendering access and egress very difficult

Unfenced swimming pool with water without life saving buoys



Passage totally blocked by debris and disorganized electrical wiring

Building waste with metal bars, PU tubings, timber wastes, etc.

Electric wiring laying along the floor





CHAPTER 5

Building and Minor Civil Work



Slip forms

Slip forms for concrete core construction on high rise buildings have been widely used in Hong Kong. The health and safety issues are quite different from the conventional formwork building. The associated hazards are different due to the use of various sets of form specifications and working systems. Most accidents occurred during lifting operations, assembly and dismantling of formwork. Most of the fatal injuries relate to fall of workers from height either from unfenced working platforms, hit by lifting loads, or a combination of both.

Although the use of slip forms can reduce most of the scaffolding and working platforms at the external wall of the structures under construction, depending on the specification, size or configuration of the building under construction, there are variations leading to different practices. Some of these hazards and risks associated with the erection, operation and dismantling processes are often ignored. Another issue of concern is unauthorized variations to forms or supporting structures, which can affect their stability or structural integrity, thus causing injuries as the structures collapse.

Health and safety issues associated with slip forms include:

- risk of manual handling injuries from working in tight spaces where movement and headroom is restricted
- access to, and egress from, these structures
- access to, and egress from, the working platforms within the structure.

Designers and manufacturers of slip forms need to ensure that the design, structure, associated scaffolds or working platforms intended to be used do not create a safety risk. In developing a safe system of work, they should take into consideration the hazards and risks associated with different types of slip forms used for concrete core construction.





Designers

Designers of slip forms must ensure that the design of the structure does not contribute to the risk of injury during their installation, operation and dismantling.

During the design phase, they should identify any hazards, assess the risks and eliminate them. Where this is not practicable, they should clearly specify the necessary measures to reduce any risk so far as is practicable.

The identification of hazards should include any dangerous manual handling such as shutters, hanging brackets and other components of the system.

The designer should also:

- clearly define the proper use of the system, including any necessary restrictions,
- document the identification of hazards and the assessment of risks, and the information about controlling risks,
- provide the above information in writing to the manufacturer/erector of the structure,
- advise that all variations to the design should be authorized to ensure that its structural integrity has not been affected.

Manufacturers

Manufacturers of the structure need to identify any hazards in the design, assess the risk and eliminate them. Where this is not practicable, they should list the measures necessary to reduce the risk during their erection/dismantling and operation.

This would include minimizing the risk of injury by:

- providing for safe access to all areas and working platforms,
- controlling risks associated with working at height,
- providing sufficient working space and headroom, and
- specifying the recommended manual handling method for shutters and other components.





This process should be documented and the information provided to the owner/erector.

Contractors

In developing a safe system of work for slip forms, a contractor in a construction site where the system is being used needs to ensure that the slip forms are assembled according to the designer's specification and that any variations to the design involving load bearing structure have been authorized by the designer.

The following matters also need to be taken into account in developing a safe system of work

- supervision
- where the structure is being erected by the workers, erection and dismantling should be supervised by personnel with knowledge of the structure and its operation.

The system should be operated by employees with knowledge of the operation manual for that slip form.

Before erection, dismantling or climbing takes place, workers not involved in these operations must be cleared away from the structure to protect them and the general public from any dangerous occurrence.

- training

All people involved in the climbing of the structure should be trained to:

- recognize any abnormal situations arising during the operation, and
- follow the necessary procedure when any abnormal situation arises.

Persons operating the slip form should be trained in the inspection and routine maintenance of the critical components of the structure.





Commissioning

Once all parts of the structure have been assembled in accordance with the manufacturer's instructions, and before productive work commences, the slip form should be subjected to the following process,

- a competent person, such as a structural engineer, should "sign off" that the structure has been correctly assembled; and that
- the load transfer mechanism is in order as specified by the designer
- all operational checks should be successfully performed.

Access

- Access to the top working deck should be by an external or internal trailing scaffold and stairs from the lobby or floors. Ladder access should only be used if the construction cell is too small for stairs.
- Internal access down to construction cells and trailing decks within the slip form may be by ladder or stairs.
- Guardrail or trap door protection should be provided against all penetrations
- Access should be maintained and kept clear at all times.

Preventing falls

Falls should be prevented by providing:

- systems such as guardrails, toeboards, screens and flaps inside and outside the structure,
- covers for penetrations and having procedures for passing materials through to the lower decks,
- guardrails and continuous floors at every corner of the mid-platform, and
- sufficient overlap of scaffold planks at each hanger bracket.

Preventing manual handling risk

Provide sufficient working space and headroom during operations so that workers can move through the structure without having to stoop to avoid hitting their heads.

- Where necessary, modify methods for the handling and fixing of reinforcement rods to eliminate or minimize the risk of musculoskeletal disorders to steel fixers.





Controlling operational hazards and risks

- Adopt methods to move shutters in and out that eliminate or minimize the risk of musculoskeletal disorders.
- Where necessary, modify methods for the handling of scaffolding brackets and other mid-platform components to eliminate or minimize the risk of musculoskeletal disorders.
- Secure wind walls to prevent snagging by crane hooks.
- Ensure materials on the decks below wind walls are clear of the external perimeter to prevent snagging when lifted.
- Positively secure external wall rollers to prevent them from falling onto working decks.
- Check welds and the integrity of structural components to guard against failures.
- Strictly control crange and the landing of materials on the main working deck to prevent overloading or severe impact loads.
- Strictly control concrete boom placement.

Lighting

Provide appropriate lighting for:

- external and internal access to cell and trailing deck working areas, and
- all tasks performed in all areas of working decks, internal cells and trailing decks for all conditions.
- artificial lighting must be set up so as to avoid glare or deep shadows.

Other safety issues

- Maintain a communications system at all times because the structure is isolated from other work areas.
- Establish specific and purpose-designed areas to store materials such as reinforcing steel, oxyacetylene sets and other dangerous goods.
- Provide adequate amenities for workers on the structure. Alternative arrangements may be provided, depending on the size, configuration, positioning and layout of structure where there is clear access to and from the structure and trailing decks.





- Provide appropriate fire protection for all work areas.
- Frequently monitor the appropriateness of the control measures specified in the risk control plan, and promptly modify any measures that are found to be unworkable.

Where system design shortcomings have been identified, employers should inform the designer or manufacturer to enable design improvements to be made in the future to eliminate or further reduce the risk of injury.

Column structure construction using slip form. Working platforms erected to facilitate work to move around the head safely



Self climbing formwork system





Traditional formwork system

Safety net to enclose staircase .

Temporary fencing.



Curtain wall installation at the external wall of the building under construction

Safety net to protect falling objects.



Measures to prevent falling objects

Column structure using slip form

Safety nets with opening for materials

Curtain wall installation





Disposal access not properly fenced and toeboard missing

Refuse tipping not properly designed.



Tower cranes and lifting operations

Tower cranes with fixed jib are commonly used in building sites. Accidents involving tower cranes as well as mobile cranes are not uncommon. Following the introduction to amendment legislation and code of practice in recent years, coupled with considerable effort in education, training, publicity and certification of workers, the number of fatal accidents has decreased sharply.

The causes of tower crane and mobile crane accidents are quite varied. Most tower crane accidents happened during the erection, climbing (up and down) and dismantling. The term “climbing” with respect to tower cranes is the process whereby an entire crane is raised on or within/outside a structure that is under construction. It generally refers to changing the height (up or down) of fixed tower cranes. Climbing of tower crane is more accident-prone.

Mobile crane accidents are mainly due to overturning, failing of jib as a result of unauthorized assembly or modification of the lattice not according to the manufacturer’s specifications or misuse by crane personnel or operator, e.g. using the crane’s counterweight instead of a vibrator to pull sheet piles, thus causing the mobile crane to tip forward.

Another common cause is overloading due to unauthorized defeat or alteration of the automatic load sensing device. In March 1999, a newly commissioned heavy-duty truck-mounted hydraulic crane at a marine base suddenly overturned while in operation, leading to the death of a marine police officer.





Accidents can happen to mobile cranes engaged in large scale foundation work as a result of collision of jibs resulting in the cranes overturning.

Statutory requirements on tower and mobile cranes are clearly laid down in “*The Code of Practice for Safe Use of Mobile Cranes.*” and “*The Code of Practice for the Safe Use of Tower Cranes*” published by the Labour Department. The purpose is to assist duty holders to comply with the provisions of the Construction Sites (Safety) Regulations and the Factories and Industrial Undertakings (Lifting Appliances and Lifting Gear) Regulations. These guides provide guidance on the safe application and operation of mobile cranes and tower cranes to ensure the safety of employees working at or in close proximity to a moving crane.

Apart from the general requirement of a safe system of work which should cater for the safe lifting operation and the safety of non-operators, the Code also provides guidelines regarding the safe distance between the crane in operation and other non-operators in different situations.

The Code addresses in detail the following issues –

- Management of the lifting operation
- Planning of the lifting operation
- Responsibilities/requirements of personnel
- Selection of tower cranes
- Markings and documentation
- Operation features of tower cranes
- Siting of tower cranes
- Erection and dismantling
- Procedures and precautions
- Safe working loads and operating conditions
- Maintenance
- Inspection, examination and testing
- Securing of loads before lifting
- Recommended hand signals
- Frequency of test, thorough examination and inspection of tower cranes under LALGR

Apart from statutory requirement and the Code, the industry has in recent years successfully developed a number of good safety practices to enhance the safe use of tower cranes and lifting operations:





Adjustment and maintenance

For adjustment or maintenance to be performed safely, some improvements have been devised (apart from the standard design by the manufacturer) on access walkways, handholds, footholds, safety lines, or other safeguards as necessary to eliminate the hazard of falling from a crane.

Safety devices and signaling aids.

The development and implementation of additional active systems which prevent cranes from exceeding their safe performance envelope have contributed to significant decreases in the number and severity of crane accidents by minimizing the opportunity for human errors. These safety devices include CCTV, anti-collision device (to prevent overlapping loads and collision of jibs of cranes), wind speed detection device, visual warning devices, audible signals and automatic stops, which operate in relation to rated loads, limit devices, and constant pressure control devices.

Crane Anti-collision System

Worksite with a large number of tower cranes



Tower cranes should be equipped with anti-collision device





A tower crane in the course of erection



An anti-collision and zone protection system for tower cranes was introduced by a French contractor in 1999 to its building sites



To enhance the safety of the working environment by:

- management of interference between tower cranes - Automatic prevention of collision when cranes over-fly each other
- automatic prevention of over-flying of sensitive or prohibited areas

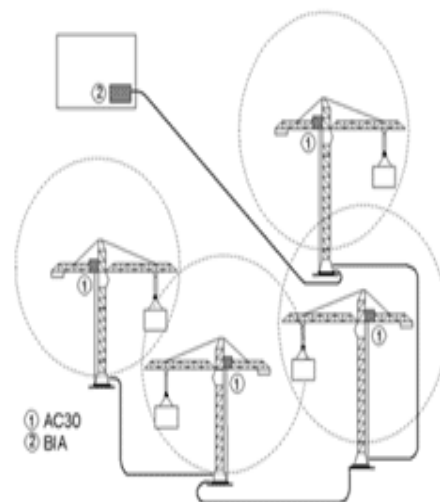

**Characteristic of the system:**

- The system capacity is up to 20 cranes on a single site with 5 cranes operating in the same working area works. It works with a pre-set working zone for each tower crane
- Defines restricted zones e.g. above site office, bridges or roads
- Allows operation at maximum safe speed with smooth stoppage
- Computerized indicator in cabin can show approach of other cranes
- Radio communication can be wired or wireless.

General Safety hints for cranes and lifting operation:

- Plant and equipment in good condition
- Daily safety inspection procedures/checklists
- Fault reporting/rectification system in use
- Operators trained and licensed

Warning and instructions displayed

- Warning lights operational
- Reversing alarm operational
- Satisfactory operating practices
- Fire extinguisher
- Tyres in place working satisfactorily
- Safe Working Load of lifting or carrying equipment displayed
- Permit to work or lifting certificate for heavy and/or complicated operation (practiced in West Rail Projects and projects with extensive heavy lifting or civil works)

Wind speed & load indicator
inside tower crane cabin





Prefabricated formwork

The application of precast formwork requires efficient planning and coordination among the client, architect, engineer, builder and manufacturer of precast elements. It is widely adopted by major local builders in recent years in residential buildings.

Using prefabricated formwork, it is necessary to allow sufficient lead-time for planning, production, testing and quality control before actual site works are carried out. Collaborative effort from all parties is required.

One of the unique features of using prefabricated formwork is less scaffolding and temporary works at the site. As a result, the risk and hazard control in this respect can be substantially reduced. Works that cause nuisance are managed in the formwork factories. Debris at site and hygiene conditions can also be more easily managed.

Safety checklist for formwork operatives

- Check all constructed formwork. Make sure that it is of the same type and capacity as specified in the design drawings and is erected in accordance with the design.
- The work method used should correspond with specifications, and should be secured to avoid workers from falling.
- When laying additional sheets from the formwork deck, workers should stay clear of the leading edge, pushing out the sheets as they go.
- All edges should be well protected.
- Ensure safe and secure access and egress to and from all the formwork areas.
- All protruded starter bars should be protected.
- All formwork shutters need to be secured before they are being lifted up.
- Weather conditions such as strong winds should be monitored.
- No worker should be allowed to access the immediate area beneath the section of formwork during lifting or when concrete is being poured.





Slip form for the central core with temporary fencing



The steel wallform arrangement for the wing construction after reinforcement fixing



Safe working platform on the external wall while lifting and fixing of the precast facade into position is in progress





The wall reinforcement bars overlapping with the starter bars of the precast façade forming a fence for edge protection



Working platform with fencing in position while the lintel beam reinforcement work is in progress



A close-up view of the working platform during the installation of precast façade and the reinforcement fixing of the wall at the rear side





Precast façade storage area



Hoisting a precast façade



Additional safety chain for safe lifting of facade

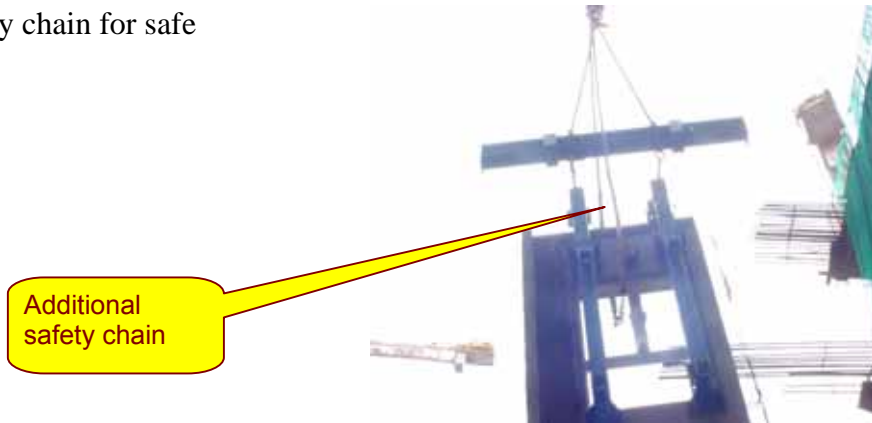



Lifting façade in position



Dismantling of strong back



LCD display inside tower crane cabin for safe lifting





Rubber tires bumper for safe lifting of façade and other panels



TV monitor to facilitate safe lifting operation



Safety net to protect operations below

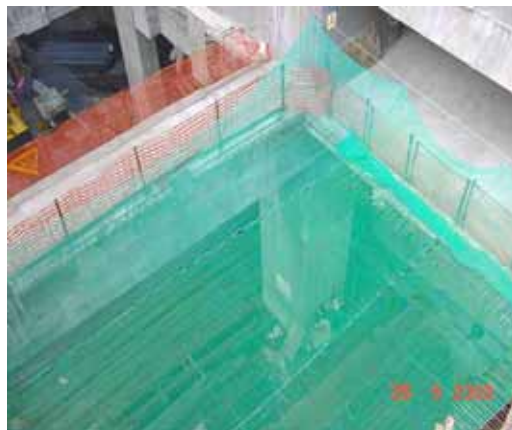



External wall working platform with railings and safety net



Metal mould platform with handrail and wire net fencing



Safety net to protect unfinished window facade





Erection of the first section of climb form at the ground level (IFC)

Fencing of platform while formwork erection was in progress.



The first section of core wall (western section) being concreted while the erection of the eastern section was in progress



Close-up view of the formwork system used for the construction of the core wall. Another climb form set would be used to replace this when the core wall reached ground level





Detail of the south elevation of the transfer truss

Fenced working platform



Forming the transfer truss at its early stage

Deck had yet to be fenced before any work began



Main activities on the steel form (Charter House)

Workers working along the steel columns

Partially covered perimeters





Unfenced edges of workplaces

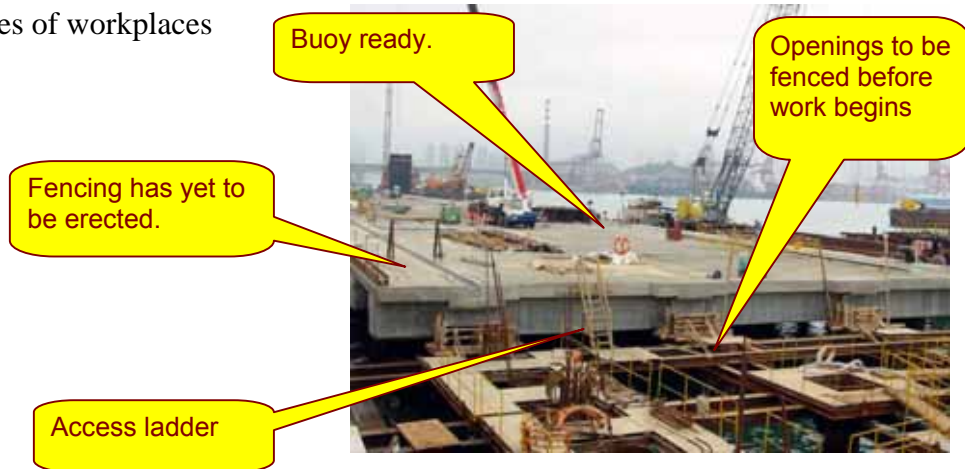

Substandard working platforms



Scaffolds

A scaffold includes any temporary structure on or from which persons perform work, any temporary structure which enables persons to obtain access to or which enables materials to be taken to any place at which such work is performed, and any working platform, gangway, run, ladder or step-ladder (other than an independent ladder or step-ladder which does not form part of such a structure) together with any guard-rail, toe-board or other safeguards and all fixings. A contractor has to make and keep every place of work on construction site safe, and in particular, to take suitable and adequate steps to prevent persons from falling from a height of 2m or more from any of these structures.

A Code of Practice (COP) for Bamboo Scaffolding Safety has been issued by the Labour Department to enhance the work safety and health in bamboo scaffolding. The COP aims to provide practical guidance for compliance with the relevant requirements under the FIUO and the Construction Sites (Safety) Regulations. The COP gives a





summary of the statutory provisions in relation to bamboo scaffolding, particularly the responsibilities of both the proprietors and the employees in ensuring safety and health at work. It advises on actions to be taken to manage safety and health at bamboo scaffolding work, covering such areas as proper planning to minimize work hazards, criteria in selecting a subcontractor, site management, monitoring of safety performance and training of bamboo scaffolders. Other areas included are technical requirements in constructing bamboo scaffolds, their maintenance, inspection and dismantling.

Apart from this, a Code of Practice entitled “Code of Practice for Metal Scaffolding Safety” has also been issued by the Labour Department to provide practical guidance in ensuring the safety and health in works relating to metal scaffolding. In this context, metal scaffolding refers to scaffolding with metal components as structural skeleton..

The Buildings Department has also published a COP entitled “Code of Practice for Demolition of Buildings”. This Code of Practice sets out, among other things, the occupational safety and health aspects of scaffoldings in some detail, including screen covers, catch fan, hoarding, covered walkway, temporary supports and debris and waste chutes.

Working platforms

In order to provide a better protection to persons working on construction sites Part VA of the Construction Sites (Safety) Regulations (the Regulation) has been revamped. The amended Regulation spells out the broad principle, namely the contractor has a general duty to make and keep every place of work on construction site safe, and in particular, to take suitable and adequate steps to prevent persons from falling from a height of 2m or more.

According to “A Brief Guide to the Provisions for Safe Places of Work” under Part VA of the Regulation, the requirements for working platforms, gangways and coverings, etc. are –

- | | |
|---|--|
| Width of working platforms, gangways and runs | <ul style="list-style-type: none"> ▪ not less than 400 mm ▪ not less than 650 mm for gangway or run used for movement of materials |
|---|--|





Construction of working platforms, gangways and runs

- closely boarded or planked (a working platform, gangway or run -
 - consisting of open metal work having interstices none of which exceeds 4000 mm² ;
 - the boards or planks forming it are secured to prevent movement and the space between adjacent boards or planks does not exceed 25mm
- need not be closely boarded or planked if there is no risk of persons below it from being struck by materials or articles falling through the platform, gangway or run)
- boards or planks forming platforms etc.
 - of sound construction, adequate strength and free from patent defect
 - not less than 200 mm in width and not less than 25 mm in thickness or not less than 150 mm in width when the board or plank exceeds 50 mm in thickness
 - not protruding beyond its end support to a distance exceeding 150 mm
 - rest securely and evenly on its supports
 - rest on at least 3 supports

Coverings for opening

- so constructed as to prevent the fall of persons, materials and articles
- clearly and boldly marked as to show its purpose or securely fixed in position

Height of toeboards

not less than 200 mm in height (toe-boards are not required for stairs)

Height of guardrails

The height of a guardrail above any place of work on a working platform, gangway, run or stairway shall be

- top guardrail : not less than 900 mm and not more than 1150 mm
- intermediate guardrail : not less than 450 mm and not more than 600 mm





For working platforms on bamboo scaffolds, these height dimensions may not apply if the platforms are protected by not less than 2 horizontal bamboo members spaced at intervals between 750mm to 900 mm.

General safety hints for platforms and scaffolds:

- Provide safe access to and egress from all platforms.
- Keep all work platforms free from load, such as construction wastes.
- Suitably place platforms on sound base, such as scaffolds, to prevent displacements.
- Prevent movement or tipping, especially surface dirt of platforms.
- Erect and dismantle scaffolds and platforms only under the supervision of a competent person.
- Each scaffold must be capable of supporting the load intended.
- The competent person must inspect scaffolds before each use.
- Use sound base plates to level or stabilize the footings.

Planking

- Closely plank a scaffold to provide a safe working platform. The working platform decking must be free from patent defects.
- Extend planks or decking material sufficiently over the edges or cleat them to prevent displacement. Avoid over extending the platform beyond the end supports to prevent tipping when workers are stepping or working on it.
- Avoid over extending the platform beyond the end supports to prevent tipping when workers are stepping or working on it.
- Be sure that working platforms are of a proper size and, for metal scaffolds, end hooks are available and attached to the scaffold frame.





Guardrails

- All working platforms should be safe, with a standard guardrail practical for the job. Otherwise, use other fall protection devices such as safety harnesses with lanyards and safety nets.
- All guardrails should be provided with a midrail.
- Toe boards on standard working platform are also required.

Properly fenced working platforms.



Safe working platform and gangway.

Toe board.

Closely-boarded working platform.





Safe working platform and gangway.

Adequate headroom for safe working.

Nylon net to prevent loose objects from falling over.



Safe working platform and fan set up.

Safety catch fan for adequate protection.



Safe working platform and catch fan set up.





Adequate fencing walkway with netting to prevent falling objects.



Suspended working platforms

Suspended working platforms, also commonly known as gondolas are widely used in Hong Kong. They carry workers, site personnel and engineers for working at height during the installation of curtain walls and windows, window cleaning, external renovation and decoration of buildings, bridges, chimneys, silos and other structures.

The safety of workers working on suspended working platforms depends very much on whether there is a safe system of work, thorough examination and weekly inspection. Common causes of accidents include tilting of the platform caused by poor maintenance, poor work practices, or operating under adverse weather conditions. Since most workers wear safety harness as required by law, fatal cases have been reduced in the past few years.

For detailed statutory requirements, it is useful to refer to the Code of Practice issued by the Commissioner for Labour. It provides practical guidance to the owner of a suspended working platform for compliance with the requirements under the provisions of the Factories and Industrial Undertakings (Suspended Working Platforms) Regulation.

Material hoist

Apart from working platforms and bamboo scaffoldings, material hoist was one of the three major sources of fatal site accidents resulting from fall of person from height.





Material hoist is a plant commonly used on construction sites for material transportation. In the past, most accidents were attributable to the misinterpreting or misunderstanding of the instructions or signals between the users and the operators of hoists. A common accident scenario was that the platform/skip of a hoist suddenly moved while loading or unloading was in progress. That caused the worker using the hoist to fall into the hoistway arising from loss of body balance at an unfenced edge, or being trapped by the moving part of the hoist.

In recent years, tremendous effort has been made in improving the use of equipment. The most common device currently in use is a set of interlocking landing gates. The design concept is to equip each hoistway gate with interlocking device such that the hoist is operable only when all gates are kept closed. However, past experience had shown that certain hoistway gates were not installed with any interlocking device; or where a hoistway gate had been equipped with an interlocking device, the design and installation of the device was vulnerable to external interference. The most common one was jamming of the interlocking device thereby defeating the purpose of keeping all gates closed before the hoist could operate. For maintenance and repair projects, these problems are very often being overlooked. For some minor scale maintenance jobs, local made makeshift material hoists without any safety considerations should be discouraged. A special guide "Interlocking device on hoistway gates" published by the Labour Department outlines the technical details for their installations.

Safety training and communication to the frontline workers are essential in the management of material hoist. Site management should plan and design at the initial stage before any material hoist is installed. Detail specifications and method statement should be incorporated. After the erection, the equipment should be regularly inspected and maintained by competent persons. Competent persons should pay special attention to alterations and additions, e.g. deterioration of fencing at the loading and unloading points, erection of additional lifting appliance/gears such as Chicago boom, etc.





Properly fenced material hoist

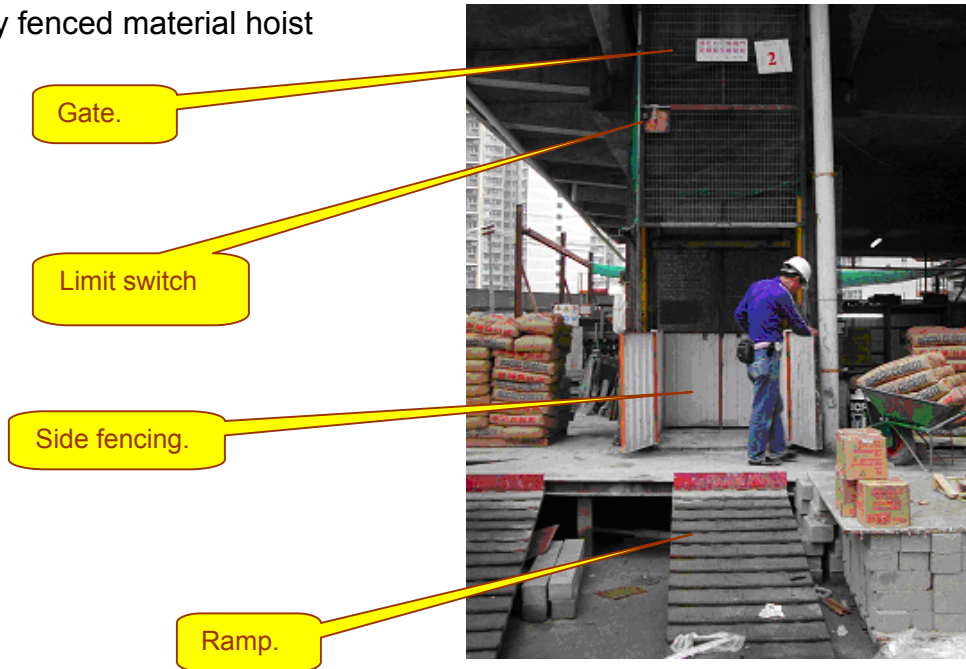

Loading building materials onto the material hoist deck.



Temporary works

Temporary works is used to support a permanent structure while it is not self-supporting, such as commonly used in situ concrete, precast units and steelwork, or commonly known as “falsework”. Any failure of falsework may lead to the collapse of the permanent structure. This could cause injury or death to those working on or near to it, as well as loss of time and cost.

Locally, falsework is commonly used in building construction, maintenance and refurbishment works. A falsework that collapses during dismantling or erection can





bury workers amidst the wooden formwork and uncured cement.

The cause of such accidents could be due to one or a combination of the following:

- no approved or calculated drawings,
- the drawings were not carefully prepared, such as neglecting the weather conditions or wind effects of the site, vibration caused by other construction operations nearby and ground conditions,
- the falsework was not erected by a competent person,
- erection or dismantling was not supervised by a competent person,
- the falsework was not checked by a competent person before being used,
- the falsework was illegally altered,
- overload of the falsework by unintended loads or unauthorized jobs by other subcontractors,
- the falsework was not regularly checked and maintained,
- no safe system of work

Another reference document “*Code of Practice for Metal Scaffolding Safety*”, also published by the Labour Department in August, 2001, provides detailed practical guidelines on falsework safety for the building industry.

Safe use of suspended working platform

Toeboard and midrail in place.





Safe use of suspended working platform



Safe use of suspended working platform

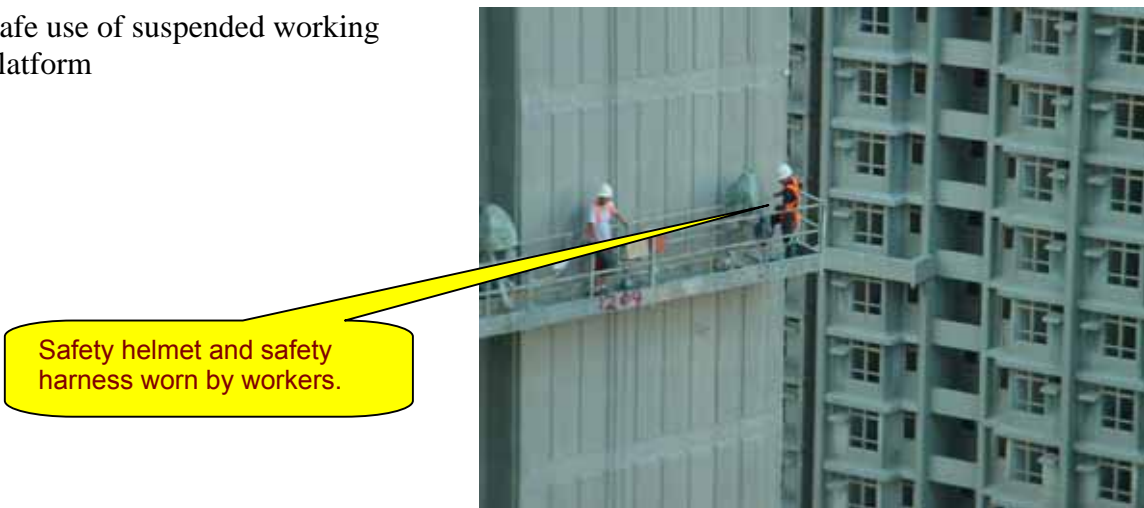

Fixing steel bars (50 mm diameter bars at the base section) around the tanchions of a column before encasing it in concrete

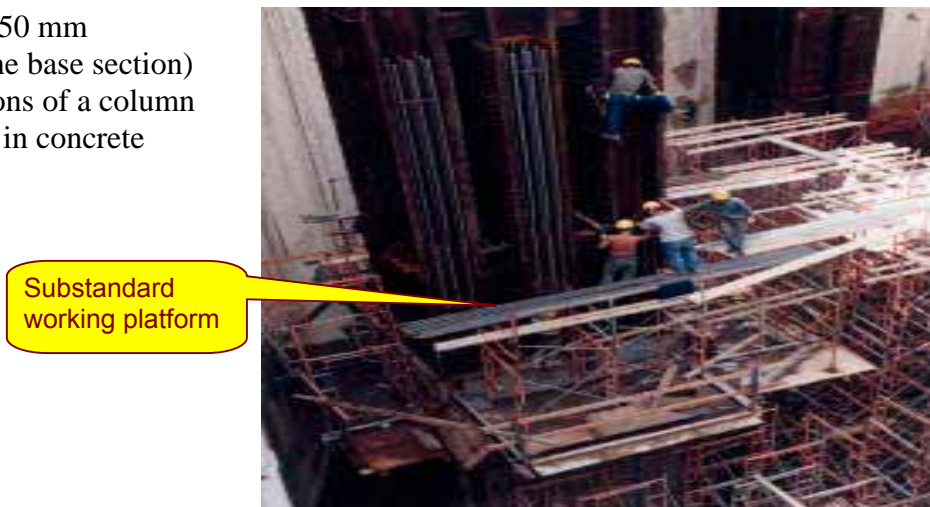



Forming the floor slab inside the cofferdam with a construction joint in place for breaking through to join to the adjoining basement floors later



Fencing of the edge.

Unplanned working platforms

The climb form, comprising two separate climb systems, was used to construct the central core



Working platforms at various decks

The transfer truss supporting two secondary columns at each corner of the building's external frame



Fenced external frame





A view of the climb form at a building corner when it was in the released position ready for lifting to the next working level



A 24 m edge beam spanning between the mega-columns at the lower section of the tower. The beam sections were gradually reduced in size for higher levels



Concreting to the composite mega-column



Improper working platform





Two sets of climb forms for the mega-columns on the building exterior

Temporary working platform



A mega column with the reinforcing bars fixed in position and ready for the concrete encasement

Barrier of insufficient height on both ends.



Building elevation showing the basic configuration of the transfer/belt truss

Decking not yet planked for working.





The climb form in position ready for encasing

Fenced floor edge.



Platforms not yet fenced for workers to work on



Inadequate working platform





Inadequate working platforms



Typical substandard planks used as temporary platform



Ladders

Ladders in building operations are gradually being replaced by scaffolds, platforms and trestles over the years. However, it is still extensively used by workers involved in maintenance and interior decoration jobs, including technicians engaged in water, electricity and gas works, etc. Ladders are commonly made of timber or metal, such as aluminum folding ladders.

Accidents involving the use of ladder occurred every now and then. In a typical fatal case, a worker was assigned by his employer to repair a ceiling light flushed into a metal grid of the false ceiling. He was standing on an aluminum ladder to reach for the light box. While he was inspecting the wiring above the false ceiling, he might have come into contact with the earthed metal casing of the light box. Possible live conductor might have come from the faulty earthed metal light box casing, or from some faulty electric wirings above the false ceiling. After careful examination, the aluminum ladder might have been energized by a faulty electric wire on the floor, near





one of the footings of the ladder. The rubber footing of the ladder was missing. It was suspected that this was the source of energy causing the accident. To complete the circuit, current was passed onto the ladder, through the body of the worker and to the earthed metal casing of the ceiling light, leading to electrocution.

Data from the Health and Safety Executives in the United Kingdom on the fatalities in the construction sector between 1997 and 2001 showed that the most common cause of fatal accidents resulting from falls within this sector occurred as a result of a fall (52%). Of this, 23% were falls from ladders, although the type of ladder involved was not specified. The occupational groups most affected were painters and decorators being the most common victims of fatal falls from a ladder.

Ladder Design

The US Department of Labor's Occupational Safety and Health Administration (OSHA 3124 1997 (Revised)) recommended, among other things, the use of ladders where the desired rise from the horizontal is at an angle of 50° or more, or where a stairway is not practical; use a stair ladder for inclines between 50° and 75°; the use of a vertical ladder for angles greater than 75°; the use of stairs for rises between 20° and 50° and the use of ramps for inclines less than 20°.

As there are very few detailed references for ladders, the following extracts from the US OSHA publication are reproduced for reference.

Ladder Design Principles

- The first step from the ground must be reachable by the shortest expected user, and at least two handholds must be accessible to this person while he or she is still on the ground.
- The steps or rungs must accept the user's shoe, with the shoe being placed for a firm step; i.e., the midpoint of the shoe, not just the toe, must rest solidly on the step. Each step or rung should be sufficiently wide so that the person can stop and rest both feet on it.
- Plan the position of each succeeding step and its associated handhold so that the user's final entry into the vehicle will be compatible with sitting in the seat. Remember that when a person climbs a ladder, the hand and leg that are making the next move are on opposite sides of the body. If handholds and steps are not planned to conform to this natural "climb pattern," the person will more than likely end up with the wrong foot ready to enter the workstation; i.e., usually a person cannot hold and step from the same side





without swinging. Do not create a system that forces the user to step on a hubcap, tire, or other irregular surface.

- Provide sufficient clearances for a person exiting the workstation to turn around and face a vertical ladder to climb down.
- The specific contour of handrails must follow the gripping, pulling, and supporting patterns associated with both entry and exit; entry and exit are generally quite different and sometimes require more than one handrail geometry.

Non Vertical (Stair) Ladders

Non vertical ladders should have flat horizontal treads (as opposed to round rungs) and two handrails. The most familiar example of this type is the ship's ladder, which usually rises at an angle of 68° from the horizontal (50° - 60° is a preferable range), with a clearance for only one person. Use separate up and down ladders for simultaneous two-way traffic. Two-way ladders should use a maximum tilt angle of 60°, preferably with a double handrail in the center:

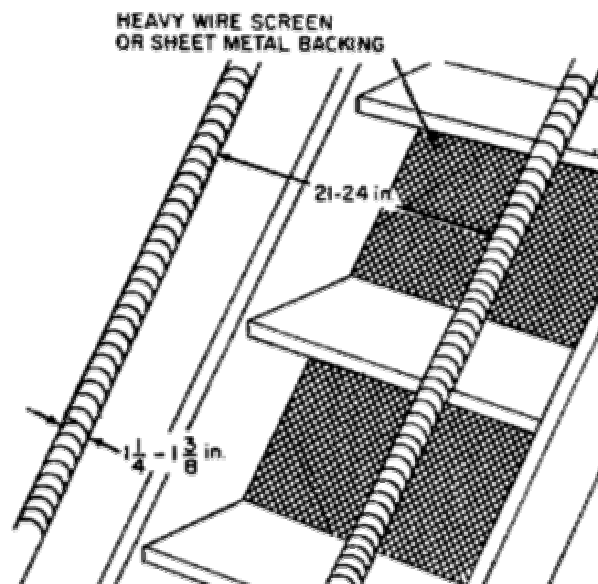

Non vertical ladder dimensions
(OSHA)



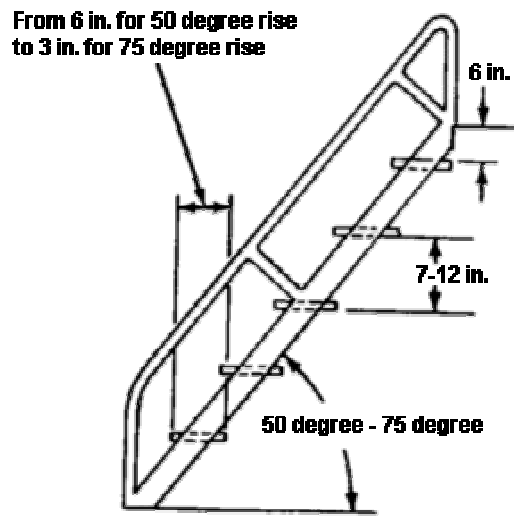

Handrail arrangement.
(OSHA)

Vertical Ladders

Use round rungs to provide both hand grips and foot supports for vertical ladders (inclines between 75° and 90°), as shown below -.

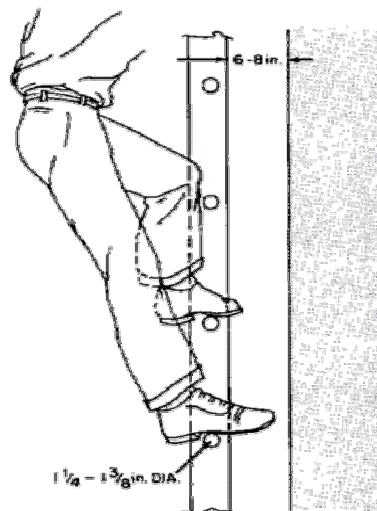

Vertical ladder design.
(OSHA)



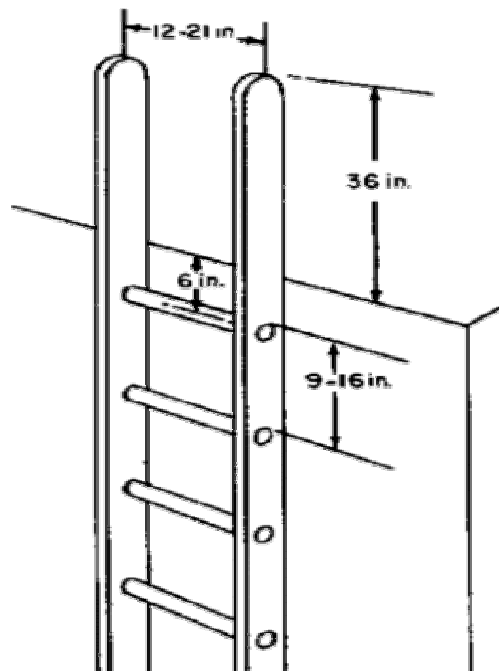

Vertical ladder design.
(OSHA)

Stairs

Stairs should rise from the horizontal at an angle of between 20° and 50°. The preferred angle is between 30° and 35°. This rise angle automatically determines the ratio of riser height to tread depth, but the minimum riser height should be 5 in.

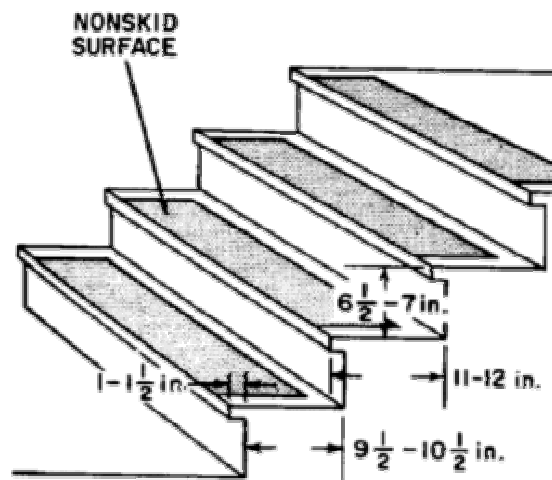

Stair tread dimensions.





Avoid long continuous flights of stairs. Where space permits, provide landings every 10 to 12 treads. In addition, enclosed stairs should have a handrail on at least one side. For open stairways and landings, provide a guardrail halfway between the handrails and treads. In addition, provide screen guards between the guardrail and floor for landings where the stairway is at right angles to the landing.

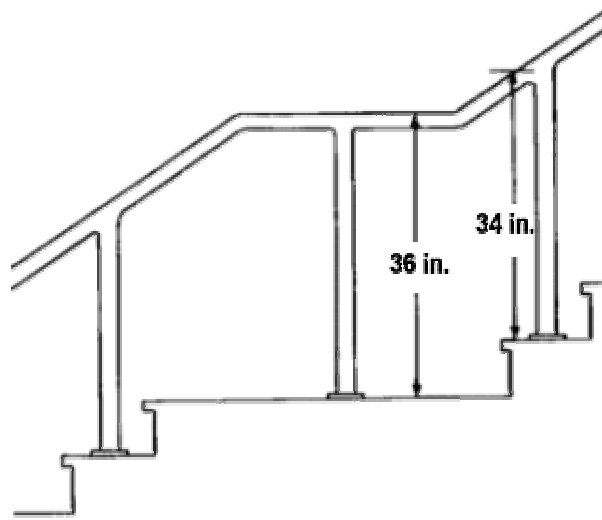

Recommended handrail heights.
(OSHA)

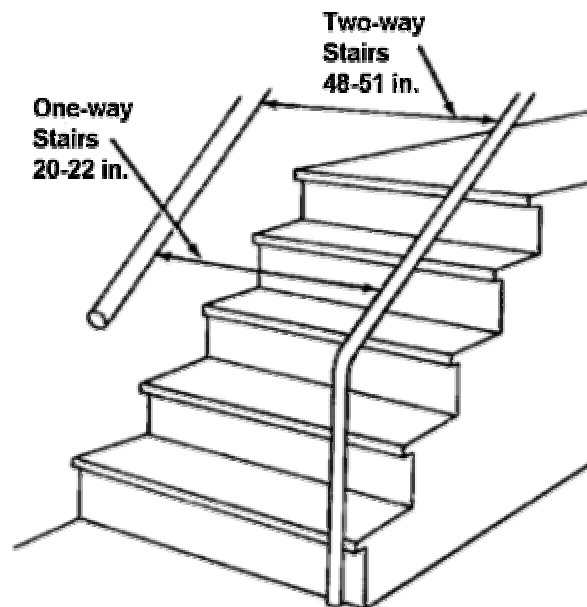

Recommended stair widths between handrails.
(OSHA)



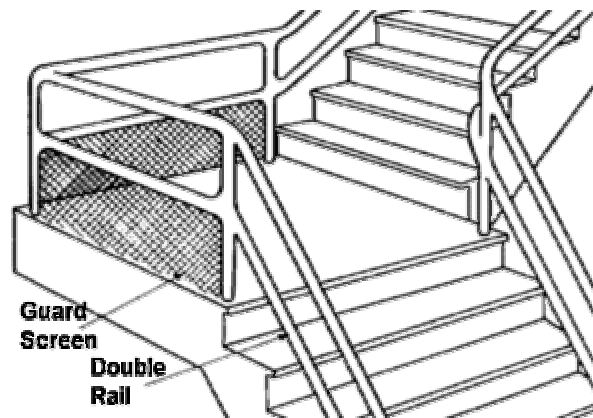

Use of guards and guard rail when stair flights are at right angles.
(OSHA)

General safety hints

- Ladders should not be used for supporting loads.
- Straight or extension ladders securely fixed at top.
- For extended heights, such as lamp posts, consider the use of mobile scaffolds or powered platforms.
- Never use metal, aluminum or other conductive ladder near electrical installations or live exposed electrical equipment.

Maintenance

- Secure ladders near the top and/or at the bottom to prevent them from slipping.
- Place ladders at the proper angle (1:4 from base to vertical rise).
- Extend ladders above the landing by 1 m.
- Avoid using ladders near busy passageways or roads with busy car traffic, use other means or otherwise fence off the area.
- Keep ladders in good conditions and free of defects.
- Check all ladders before use for broken rungs or other defects periodically.

Additional hints:

Aluminum, or any metal ladder, should not be used near live cables or equipment except in specialized work such as in high voltage substations where nonconductive ladders might present a greater hazard than conductive ladders. A proper safety system of work, coupled with a lockout system, should be in place.





Ladder access

For better protection, continuous protection such as back-loop or safety belt with anchorage need to be considered.



Stage ladder for electrician





Ladder and stairs combined



Ladder access



Tower scaffold

Ladder access.





Vertical ladder



Typical fixed inclined ladder

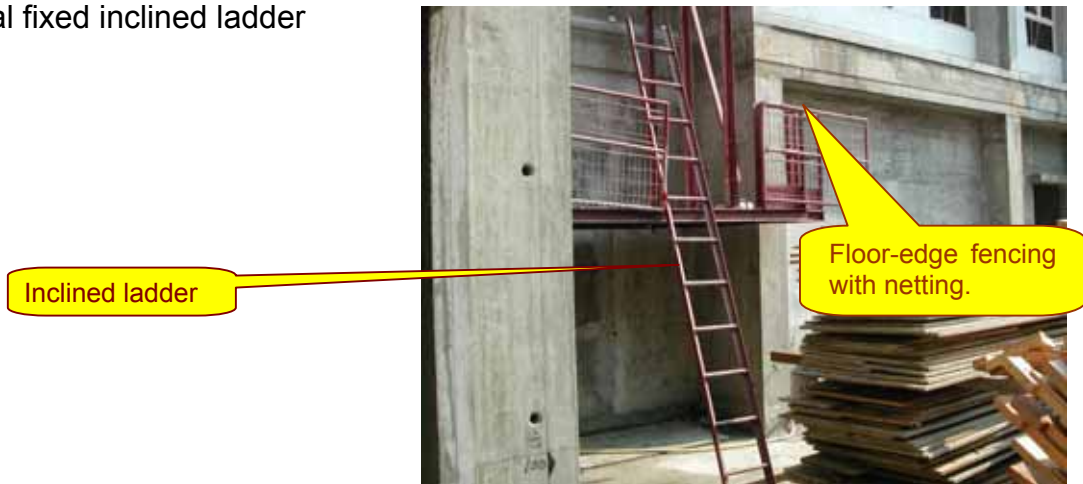

Working stage/bench with castors

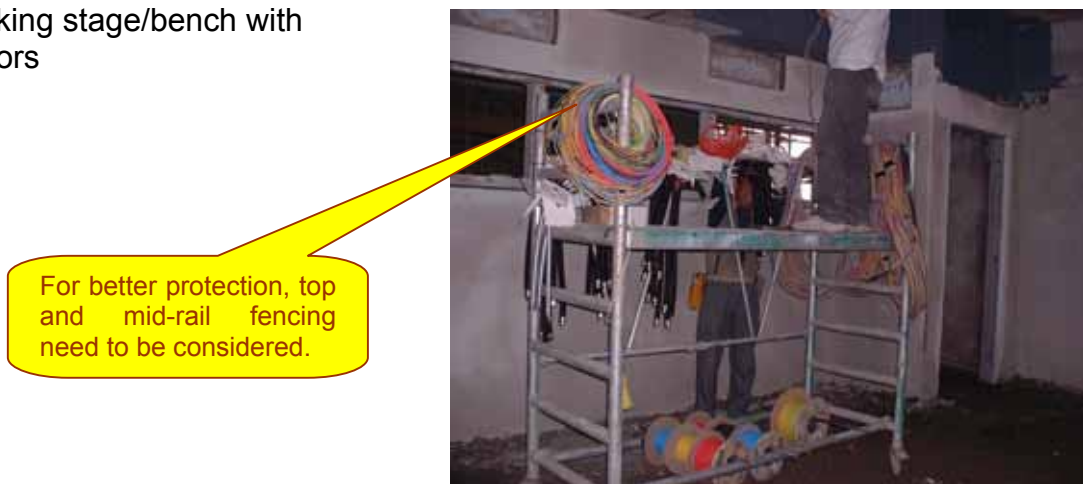



Working stage/bench



Plasterer working indoors on a work bench



Waist belt with lanyard too long.

Plasterer working outdoors on a properly fenced working platform



Harness with proper anchorage point.





Undesirable for workers working on an A-ladder especially at considerable heights

Potential danger when it is placed near loose or stacked material



Portable tools

General safety of portable power tools:

General guidelines for portable tools

- All portable tools should be properly maintained and a preventive maintenance programme should be in place to keep the equipment in good conditions.
- Never overload the manufacturer's specifications and recommendations.
- Use double insulated tools, or ensure that the tools are grounded.
- Equip all power saws with tool guards.
- All guards should be in place before use.
- Do not modify any tool, e.g. converting a portable circular saw to table-mount.
- Switch off supply immediately after work.
- Keep wooden handles free of splinters or cracks and be sure the handles stay tight in the tool.
- Workers using powder-activated tools must receive proper training prior to their use.





- Never leave cartridges for pneumatic or power-actuated tools unattended. Keep equipment in a safe place according to the manufacturer's instructions.
- Wear suitable personal protective equipment.

Electric power-operated tools

- All electric operated tools should be properly earthed by using 3-pin plug unless it is an equipment of certified double-insulated type.
- All tools should be properly checked before use with a preventive maintenance programme in place.

Pneumatic power tools

- Pneumatic power tools should be secured to the hose properly clipped to prevent 'whipping'.
- Safety retainer should be securely maintained to prevent attachments from dislodgement.
- All pneumatically driven tools should be automatic fed by design and should have a safety device to prevent it from ejecting fasteners, unless the tool is in pointing at an angle and in contact with the work surface.
- Air hose should not be used for other purposes such as clearing debris
- The manufacturer's safe operating pressure for hoses, pipes, valves, filters, and other fittings should not be exceeded,

Fuel powered tools

- All fuel powered tools should be stopped during refuel, servicing or repair.
- All fuels should be properly stored in a suitable container.
- Avoid using fuel powered tools in confined space or where ventilation of the workplace is undesirable. It should be located away from any process with naked flame, such as flame cutting and welding.





- Fuel containers should be stored in a specially designed cabinet. In no circumstances should quantities over the exempted amount be stored unless they are kept in an approved DG (dangerous goods) Store.

Hydraulic power tools

- The hydraulic fluids used should be of an approved type suitable for the specifications of individual tools.
- The fluids should preferably be fire-retarded. The manufacturer's safe operating pressures for hoses, valves, pipes, filters, and fittings should be set and locked to avoid wrong settings.

Powder-actuated tools

- Operators should be trained in the operation of the particular tool in use, and a certificate to this effect should be issued by an approved institution.
- The tool should be tested before each shift and testing should be in accordance with the manufacturer's recommended procedure. Loaded tools should not be left unattended.
- The operator must, as a good practice, empty the tools and check the safety devices after each shift.
- Return and report to the repair department as soon as defects are suspected.
- Suitable personal protective equipment such as eye protector should be provided and used during the operation.
- Tools should not be used in an explosive or flammable atmosphere.
- All tools should be used with the correct shield, guard or attachment recommended by the manufacturer.





Cartridge-operated fixing tools approved by the Commissioner for Labour pursuant to Regulation 19 of the Factories and Industrial Undertakings (Cartridge-Operated Fixing Tools) Regulations:

- | | |
|------------------------------|--|
| 1. Ramset Model J-10 | 2. Ramset Model J-20 |
| 3. Ramset Model J-30 | 4. Ramset Model JP-50 |
| 5. Ramset Model 4180 | 6. Hilti Model DX 100L |
| 7. Hilti Model DX 350 | 8. Hilti Model DX 400 |
| 9. Hilti Model DX 600 | 10. Hilti Model DX 600N |
| 11. Hilti Model DX 650 | 12. Impex Model KOMET 1B |
| 13. Omark Model 330 Super G | 14. Omark Model 330 BP4 |
| 15. Omark Model 330 BP8 | 16. Dentzer Blozensetzer Model FAVORIT |
| 17. Omark Model 330L-V | 18. Ramset Model JP-88 |
| 19. Hilti Model DX 450 | 20. Red Head Model 330 BPE-4 |
| 21. Red Head Model 330 BPE-8 | 22. Red Head Model A-10 |
| 23. Ramset Model D-60 | 24. Omark Model M3-1M4 |
| 25. Red Head Model 340 BPE-4 | 26. Red Head Model 340 BPE-8 |
| 27. Hilti Model DX 350P | 28. Ramset Model D90 |
| 29. Hilti Model DX 36M | 30. SPIT Model P60 |
| 31. SPIT Model S38 | 32. SPIT Model P110 |
| 33. Hsinho Model 660/B4/B8 | 34. SPIT Model P200 |
| 35. Ramset Model S75A | 36. Hilti Model DX35 |
| 37. Hilti Model DX A40 | 38. Hilti Model DXA41 |
| 39. SPIT Model P45 | 40. SPIT Model P230 |
| 41. Ramset Model J20S | 42. Ramset Model TS750P |
| 43. Ramset Model TS60P | 44. Hilti Model DX351 |
| 45. Hilti Model DX 750 | |

Confined space

Confined spaces are commonly found in many building worksites such as in a well, sewer, tunnel, pipe, flue, pressure receiver, hatch, caisson, shaft, manhole, storage tank or similar type of enclosure. Workers can be overcome from time to time in tanks, sewers or manholes. Without adequate knowledge of the hazards, some workers engaged in maintenance work, e.g. untrained employees of property management companies, who work in sewers and manholes are easily intoxicated and are often unable to come out by themselves. Without proper protection, co-workers can be overcome during the rescue operation.





Risk associated with confined space work

- serious injury to any person at work arising from a fire or explosion
- the loss of consciousness of any person at work arising from an increase in body temperature
- the loss of consciousness or asphyxiation of any person at work arising from gas, fume, vapour or the lack of oxygen
- the drowning of any person at work arising from a sudden increase in the level of liquid
- the asphyxiation of any person at work arising from a free flowing solid or the inability to reach a respirable environment due to entrapment by a free flowing solid

For further details, it is useful to refer to the Labour Department's revised "*The Factories and Industrial Undertakings (Confined Spaces) Regulation*", that came into operation on 19 June 2000, published by the Labour Department.

Under the regulation, it is the duty of a contractor to appoint a competent person to carry out a risk assessment for work in confined space and make recommendations on the safety and health measures before entry and undertaking the work.

Safety precautions

Before allowing workers to enter a confined space for the first time

- disconnect and lock out the power source to mechanical equipment which is liable to cause danger inside a confined space
- blank off the pipe or supply line where the contents are liable to create a hazard
- test to ensure the absence of any hazardous gas and no deficiency of oxygen in the confined space
- purge, cool and ventilate the confined space to ensure that it is a safe workplace
- provide adequate respirable air and effective forced ventilation inside the confined space
- take effective steps to prevent ingress of hazardous gas, vapour, dust, fume and in-rush of free flowing solid or liquid into the confined space
- maintain continuous communication with the workers inside





Compliance with risk assessment report and certification

- ensure that the risk assessment report and related certificate are displayed in a conspicuous place at the entrance of the confined space
- ensure that the safety precautions undertaken continue to be effective
- verify the risk assessment report submitted by the competent person
- issue a certificate stating that all necessary safety precautions in relation to the hazards identified in the risk assessment report have been taken and also the period during which workers may remain safely in the confined space before allowing workers enter the confined space for the first time
- ensure that no worker enters or remains in a confined space unless all recommendations in the risk assessment report have been complied with
- keep the certificate and risk assessment report for one year after the work in the confined space has been completed and make them available to an occupational safety officer when requested

The risk assessment report should cover

- the work method to be used and the plant and materials to be used in work activities
- whether or not there is any hazardous gas, vapour, dust or fume present or there is any deficiency in oxygen
- verify the risk assessment report submitted by the competent person
- issue a certificate stating that all necessary safety precautions in relation to the hazards identified in the risk assessment report have been taken and the period during which workers may remain safely in the confined space before allowing workers enter the confined space for the first time
- ensure that no worker enters or remains in a confined space unless all recommendations in the risk assessment report have been complied with
- keep the certificate and risk assessment report for one year after the work in the confined space has been completed and make them available to an occupational safety officer when requested





Use of personal protective equipment

- ensure the person entering a confined space or remaining therein for underground pipework, or where the risk assessment report recommends, is wearing an approved breathing apparatus of a type that gives appropriate protection given the nature of the confined space.
- where the use of breathing apparatus is required, ensure that the person is also wearing a safety harness connected to a lifeline, the free end of which is held by a person who is capable of pulling him out of the confined space
- breathing apparatus for confined space work should be of a type approved by the Commissioner for Labour. Notice of approval of these apparatus is published in the Gazette.

Emergency procedures

- formulate and implement emergency procedures to deal with any serious and imminent danger to workers inside confined space
- provide and keep readily available in satisfactory condition sufficient supply of -
 - approved breathing apparatus
 - reviving apparatus
 - vessels containing oxygen or air
 - safety harnesses and ropes
 - audio and visual alarm for alerting others outside confined space
- ensure sufficient number of persons who know how to use the safety equipment are present when work is taking place in a confined space

Provision of information and instructions

- provide all confined space workers and those assisting in such work outside the confined space with instructions, training and advice as are necessary to ensure the safety and health of workers
- provide all equipment necessary to ensure the safety and health of workers

A Code of Practice prepared by the Labour Department (*First edition June 2000*).





Confined space entry

Purging and continuous fresh-air entry, together with PPE, and winch for emergency escape.



Concrete pump

Concrete pump accidents can cause minor injuries due to low pressure whipping hoses or simply spraying the concrete around, making a mess of everything nearby. Fatal accidents had occurred during the clearing of the hoses or pipes. For example, a worker was killed when trying to remove a fixed pipe joint when a clog was suspected. As soon as the bracket was loosened, the metal pipe swiveled causing the pipe to wipe the worker directly on the body. The worker was killed by a blow between the swiveling pipe and the metal railing of the working platform behind him.

General precautions and safety hints:

- Visually check all equipment and fittings before each operation or shift.
- Place emergency shut-off device nearby.
- Provide handy wash-out water adjacent to the place of operation.
- Properly place all lines or hoses and prevent sharp bends.
- Prime, before pumping, preferably with a mixture of slurry of sand and cement ahead of the concrete.





- As far as possible, use less flexible hose to reduce the pumping pressure.
- Secure all clamps and fix all metal pipelines.
- Perform the pour as close to the pump as possible to reduce waste.
- Replace hose before each shift, remove worn-out hoses away from service to avoid increased possibility of kinking leading to vibrations and ruptures.
- Suitable personal protective equipment should be provided, such as chemical resistant gloves, aprons, rubber boots, eye protectors, etc.
- Perform the cleaning operation as soon as pumping is completed.

In case the system halts or breaks down:

- Switch off the emergency stop and cut-off the pump.
- Inform the plant operator, gang leader and/or foreman in charge
- Check for any visual defects, particularly on the hoses or joints,
- Clean out the placing line
- Clean out the pump

Additional precaution for high-rise pressure pumping

- It is a good practice to install a shut-off or switch-off valve after the pump to enable instant stopping.
- Follow the cleaning procedure to clean all pipes.
- No unauthorized worker should be allowed to add any liquid to the concrete, particularly water, as it will alter the mix which may lead to unexpected pumping pressure build-up.

Slope work

Slopes are one of the unique characteristics of Hong Kong. Public slopes belong to the Government, and they are being maintained by the relevant works department. But a number of these slopes adjacent to heavily developed areas are privately owned. In the past, slopes in Hong Kong had experienced significant failures, resulting in loss of lives and properties. In fact, Hong Kong has a history of tragic landslides, mostly as a result of failures associated with man-made cut slopes, filled





slopes and retaining walls.

The Government recorded an average of about 300 incidents each year affecting man-made slopes, walls and natural hillsides. Most of these incidents are minor. Many are just washouts and erosion on the surfaces of slopes and hillsides, but a significant proportion relates to larger failures which can threaten lives and properties, block roads and disrupt the activities of the community.

In new building developments, slope work is an integral part of the entire project. Works usually progress as part and partial of the foundation works. For slopes in existing building developments, maintenance work is often neglected by the owners, not to mention the safety and health conditions of the workers engaged in the slope maintenance work.

In a typical routine maintenance job, workers will:

- clear drainage channels, weepholes, drain pipes and slope surface;
- repair drainage channels or pavement;
- maintain damaged slope surface;
- recondition the slope surface area, such as un-grass/re-grass, tiles repair and masonry;
- remove undesirable vegetation that may damage the slope surface or cause instability;

Slope maintenance and stabilization often involve working at height. Safe access may be the first but not the only or most important problem a contractor or the management company staff has to solve. There had been slope maintenance workers being injured while working or disturbing the slope surface. Loose debris and rocks could also fall and hit the workers. The workers could lose grip and roll down together with the rocks and debris.

In 2000, the Labour Department worked with the Geotechnical Engineering Office (GEO) of the Civil Engineering Department on the minimum requirements to protect the safety and health of workers. A publication entitled "*Guidelines on Safe Access for Slope Maintenance*" was issued at the end of the joint exercise.

In this publication, a wide range of methods, some in the form of permanent access and others by way of *ad hoc* measures, are identified for access provision. It covers the hierarchy for selection of safe access methods. Some components of the safe access may reduce the visual quality of the slope and its surroundings, so the basic guidelines are to make these access provisions as inconspicuous as possible.





Access installed on a slope may lead to trespassing which is another area of concern since it involves invasion of privacy and the safety of the trespassers.

Permanent access for slope work is not a requirement by law, but such provision is ideal for regular maintenance such as clearing of drainage pipes after a rainstorm and typhoon. Considering the nature of work being performed and the geographical location of the site, powered platforms such as hydraulic platforms are also commonly used for this type of work.

For major slope repairs, proper scaffolds, working platforms and other safety measures should be set out in a proper method statement. In Part VA of the Construction Site (Safety) Regulations, a new Part VA1 of the Regulation spells out the broad principle, namely, the contractor has a general duty to make and keep every place of work on a construction site safe, and in particular, to take suitable and adequate steps to prevent persons from falling from a height of 2 m or more. Many slopes adjacent to private buildings are well above 2 m.

Apart from working at height safety, rock drillers, shotcrete nozzle operators and hydro-seeders need to be protected from noise and dust hazards during the work process. During hydro-seeding whereby slurry of seeds, mulch, fertilizers, binders and organic additives are sprayed onto the soil surface, additional protection such as ear plugs, aprons, face shields and/or goggles should also be provided.

Before work commences, conduct a risk assessment and consider the following safety measures to be provided to workers:

Personal protection

To protect skin from cement and cement grout, workers should wear:

- suitable chemical resistant gloves
- coveralls
- waterproof boots
- suitable respiratory protective equipment against dusts, e.g. cement dust
- suitable eye protectors such as shields and goggles with side-shields should be provided for mixing, grouting, or cement and other activities





Work practices

- Water sprays to minimize dust during rock drilling or rock breaking.
- Mix cement in well-ventilated areas.
- Make sure to work upwind from dust sources.
- Jack hammers or rock drilling machines should be regularly maintained to minimize noise and vibration.

Hygiene

- Provide adequate hygiene facilities on site.
- Provide facilities for cleaning boots and changing clothes.
- Don't wash your hands with water from buckets used for cleaning tools
- Clothing contaminated by wet cement should be quickly removed.
- Skin in contact with wet cement should be washed away with large amounts of cool clean water promptly.

Training and information

Provide tailor-made courses and tool box talks to workers involved. MSDS about the chemicals and materials used must be made known to the workers.

Vegetation removed and surface covered
(Source: CIVCAL)

Hydro-seeding in progress





Edges fenced on top of slope
(Source: CIVCAL)

Caisson forming a curtain wall

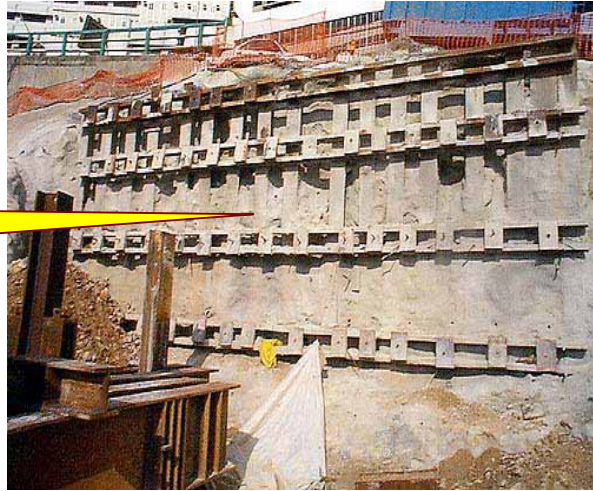

Metal scaffolding with working platforms.
(Source: CIVCAL)

Closely boarded planks



Walings with tieback anchors
(Source: CIVCAL)

Soil nailing employed to temporarily retain the soil of deep cut slopes

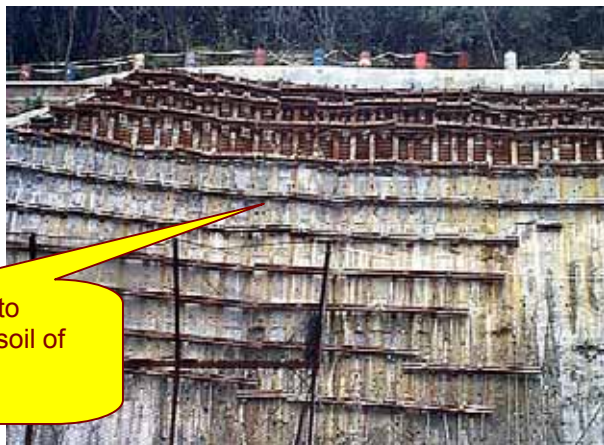



Bamboo scaffolding being erected

(Source: CIVCAL)

Fenced working platform.



Access & egress have to be improved.

Waterproof tarpaulins used for temporary weather protection

(Source: CIVCAL)

Hydro-seeding in progress



Soil and rock debris needs to be cleared regularly to avoid blockage of water drains

(Source: CIVCAL)

Chunam surface to stabilize slope.





Shotcrete used for permanent protection from water infiltration and erosion
(Source: CIVCAL)



Water spraying to reduce dust during rock drilling
(Source: CIVCAL)

Dust mask being worn.



Failed slope.
(Source: CIVCAL)





Toe of a failed slope.
(Source: CIVCAL)



Remains of a failed retaining wall.
(Source: CIVCAL)





CHAPTER 6

Maintenance Work



Maintenance work is considered generally by most people, especially in the private property sector, as a low skill job that can be handled by handymen, odd job workers or even unskilled labourers. The injury toll in the maintenance sector, very often involving fatal cases, was high and most difficult to tackle. It was not until recently that people in the industry started to manage the problems more seriously. Another problem is that the duty holders are often SMEs and self-employed.

Typical risks and characteristics identified in most maintenance work are:

- interference with other activities (e.g. presence of the public and occupants of the building);
- presence of services (e.g. water pipes and electrical cables in the floors and walls); and
- high areas, often on the external walls, posing risk of falling from heights.

The challenge of any safety professional responsible for such works is as follows:

- to ensure the compliance of the safety plan and the implementation of appropriate safety measures;
- to coordinate the work amongst different parties concerned;
- to suspend the works or remove any SME or a self-employed worker for any serious breach or non-compliance of safety rules;
- suspend any contract in the event of a serious breach of the law; and
- to suspend the works in case of imminent serious danger.

Nevertheless, there are some critical success factors in planning and executing maintenance work. These are –

- recognizing the importance of safety at the design phase;
- having collaborative management, involving all relevant persons;
- putting in place a sound risk assessment and prevention process;





- ensuring effective implementation of all prevention systems;
- motivation of all the workers and all parties involved in the project;
- ensuring effective information, training and communication; and
- monitoring performance.

Here are some examples of good trade practice –

Hoardings well-protected by nets.



Overhead protection above roads and alleys.



Notice indicating height restrictions





Hoardings well-protected by nets.



Existing facilities well-covered and protected.



Existing facilities well-covered and protected.





Lifts and escalators

A *Code of Practice for Safety at Work (Lift and Escalator)* was issued by the Commissioner for Labour under Section 7A(1) of the Factories and Industrial Undertakings Ordinance (FIUO). This Code of Practice focuses on workers' safety and recommends safe practices for proprietors or contractors to protect their employees engaged in lift and escalator works, i.e. installation, commissioning, alteration, examination, inspection, testing, servicing, repairing and dismantling work on lifts and escalators.

There have been numerous serious accidents in the past. The typical cases include:

- Case 1** An apprentice was trapped between a metal structure at the wall of the lift shaft and the descending lift car.
- Case 2** A technician was trapped between the runway and the descending counterweight.
- Case 3** A worker was trapped between the header of the doorway and the ascending lift car.
- Case 4** A technician was electrocuted while repairing the electrical circuit inside the lift car.

In 1996, a disastrous fire broke out at Garley Building in Nathan Road while lift replacements were underway. Just before the fire, the landing doors at all floors and the lift cars of two lifts had to be removed. Subsequent investigation revealed that electric arc welding work was being carried out inside a lift shaft on 15/F. The sparks and molten welding droplets ignited some combustible material accumulated within a hoarding at the 2/F landing and caused the huge fire that took away many lives. The damage was so serious that the entire building had to be demolished for redevelopment several years later.

Based on past cases, the cause of accidents falls into three main categories: trapped in fixed/moving parts, electrocution and fire. The number of accidents caused by electricity faults frequently left unnoticed because those who received electric shocks had not even been recorded, not to mention reporting to the Occupational Safety and Health Branch of the Labour Department. When the existing lifts had to be replaced as part of the building refurbishment work, additional safety precautions had to be observed.





Lessons to be learnt and/or safety precautions to be observed:

- Provide training in safety precautions associated with lift maintenance and repairs.
- Unskilled workers and/or inexperienced apprentice should be accompanied by a competent worker or lead hand.
- Permit to work or tag out system should be in place and observed.
- Warning notices should be posted.
- Turn off the system supply and work on emergency lighting or separate work light inside the lift car or lift shaft while repair is in progress.
- Risk assessment should be conducted.
- Detailed method statements and work procedures should be prepared and conveyed to the workers.
- Communication equipment such as walkie-talkie should be provided and used by workers.
- Trapping zone including machines and lift car should be securely fenced.

Contractors' responsibility

- To plan and carry out an assessment before work starts;
- To appoint suitable supervisors and engineers in writing to take charge;
- To employ competent persons to carry out the works;
- To provide information and training to the workers;
- To employ trained first aider with necessary gears and supplies;
- To ensure effective communication.

Engineers'/supervisors' responsibility

To receive safety training relating to the hazards associated with the installation, thorough examination, inspection, testing, services, maintenance, repair and dismantling of lifts and escalators and knowledge of safe working practices to be adopted to avoid associated hazards.





Site safety assessment

To develop a reliable safe system of work for lift/escalator works, an initial site safety assessment should be made on the work site by a person who is competent to do so before the commencement of every lift/escalator project. Such a person should preferably be a safety professional or an experienced engineer/supervisor, with adequate knowledge of safety and health at lift and escalator works. After making the assessment, safety and health issues should be identified and recorded. These include –

Access and egress:-

Safe means of access to and egress from each place of work should be provided [Regulation 38A of the Construction Sites (Safety) Regulations.[CS(S)R]], covering such aspects as –

- Safe access to/egress from, e.g. the machine room and the lift shaft,
- Rescue procedures and evacuation arrangements in case of emergencies
- Details of lift/escalator, control system, the type of work, etc. to be carried out
- Instruction not to allow the workers to work on live electrical equipment. If it is unavoidable, special safety precautions should be in place.
- All dangerous parts of the machinery to be effectively guarded [Regulation 44 of the CS(S)R].
- Arrangements for the use of communication equipment by the working personnel during the work to be made.
- Specify the key words/signals to be used during the communication.
- Safe manual handling procedures to be followed.

Safety guidelines on lift and escalator works:

- Safe and easy ways and access routes with sufficient headroom to the machinery spaces should be provided.
- The enclosure and supporting structure should be sound and free from defects.
- The handrail, steps, combs and drive for steps should be functioning properly.





- The braking system and the manual control and emergency stop switches should also be functioning properly.
- The protections against risks of overspeeding and unintentional reversal of the direction of travel should be checked for their effectiveness.

Safety features in the method statement after the safety assessment:

- The way in which work would be performed, and
- The number/trade of working personnel involved in carrying out the work (including those from the subcontractors) should be stated clearly.
- The anticipated equipment required to be used including the use of lifting appliances and lifting gear for mechanical handling’.
- The availability and location of secure fencing, portable access ladders, personal protective equipment such as safety boots, safety helmets, safety goggles, safety gloves, safety harnesses/belts, secure anchorage, fittings for the safety harnesses/belts, independent lifelines and etc. should be ascertained and provided.
- The time and duration available for the work to be performed should be identified and recorded.
- The number of parties, and the respective timing, working on the same lift/escalator installation should be ascertained.
- Emergency procedures and facilities, including first aid, should always be made available for dealing with emergencies on site. Such facilities should be regularly maintained and updated properly.

The safety and health management system for the control of the safety performance of the subcontractor(s), if any, should be effective and efficient. Reference should be made to “*A Guide to Construction Safety Management*” issued by the Labour Department. Generally speaking, the following factors should be considered for determining –

The nature of the task:

- The likelihood of changes in the working personnel, and
- The equipment and location of the work.





Working on lifts:

- Follow safety practices recommended by the lift manufacturers.
- Provide adequate lighting.
- Provide portable battery operated lights for workers working inside the lift well.
- The lift should be made inoperative and locked out before any work begins
- Provide safe means of access and egress.
- Provide guard for the dangerous part of any machinery.

Working on car top:

- The working personnel should be able to hold firmly on the crosshead or other rigid parts of the car structure when the car is moving. Holding any wire rope by a worker may result in serious injury and should therefore be prohibited.
- If there is an adjacent lift in the same lift well, the worker should avoid contacting with any counterweights and keep within the limits of his lift especially when the car is moving.
- As a general rule, the car top should be accessed from the top terminal landing.





Working below a lift car:

- Before entering a lift pit, the stopping devices of the lift should be tested for their effectiveness.
- If there is no direct access door to the lift pit, suitable safe means with hand holds of access to the pit should be provided from the lowest landing entrance.
- When working below a car with restrictive space which can accommodate only one person, appropriate restraint device for the lift car should be properly installed prior to gaining access into the pit.
- Worker should activate the pit-stop switch to prevent any movement of the car before entering the lift pit.
- No worker should enter or work in a lift pit with standing water.
- The shoes of workers should be free from any oil or grease to prevent slipping. Should watch out for potential tripping hazards such as oil lines or sump holes.

- Warning signs/notices should be displayed at prominent positions.





Working at lift landings:

- When workers are engaged in maintaining and examining lifts, the landing door may from time to time be required to remain open even at where the car is not there, e.g. to gain access into the lift pit or to the car top.
- Appropriate dedicated devices instead of normal hand tools should be used to keep the lift doors in an open position.
- To protect the workers at work, a fencing/barrier between 900 mm and 1150 mm in height with preferably a mid-rail and toe-board of not less than 200 mm in height should be erected in front of the entrance at the lift landing [Regulation 38P of the CS(S)R].
- The fencing/barrier should bear the relevant safety signs and warning notices in both Chinese and English to warn against the danger of removal of fencing/barrier.
- To facilitate the workers to work on the correct equipment safely, multiple lift installations should be individually identified on the lowest and highest landing entrances as well as the associated equipment in machine rooms and pulley rooms.
- When the car is not at its normal position at a landing, unlocking or opening of a landing door should only be done if it is absolutely necessary for carrying out work by the working personnel.
- Special unlocking device should be used to unlock or open a landing door and be kept in a safe place. A check should be made to ensure that the door is closed and relocked each time after use.
- Without the provision of fencings/barriers and warning signs, a landing door/gate should always be kept closed except during the short period of entering/leaving the lift well at the landing by the workers or the transportation of materials for work via the landing.

Working at height

Where work cannot be safely carried out on the ground, from any part of a building or





other permanent structure, suitable scaffolds with proper working platform(s) should be provided for working personnel [Regulation 38B of the CS(S)R]. *The Code of Practice for Scaffolding* issued by the Commissioner for Labour provides practical guidance on the construction and maintenance of bamboo or metal scaffolds.

In particular, the following should be adopted on the safe erection, use and dismantling of metal scaffolds:-

- A method statement should be prepared by a professional engineer before commencing metal scaffolding erection. The method statement should include the following:-
 - layout, support details and construction details of the metal scaffold (so that all concerned know what is to be erected and what is to be controlled);
 - justifications on the strength and stability of the scaffolding components during erection, use and dismantling;
 - sequence of erection and dismantling; and
 - standards of materials and workmanship.
- The professional engineer as mentioned in (a) above should have adequate training and practical experience to make decisions on whether the loads on the scaffold or on the supports can be resisted safely without undue movements.
- The method statement for metal scaffolds supported by fastenings (or anchors) to concrete or masonry should be checked by a qualified engineer in the structural discipline or equivalent.

Safety nets

The use of safety nets would be a better alternative than the use of safety harnesses in certain instances. Some of the examples are as follows:-

- Hazards and the use of safety harness are deemed impractical or not feasible where many workers are working in one location, or
- where large open areas or long loading edges expose workers to height under a work method, the work of erecting and dismantling of safety nets should be carefully planned and supervised, to be undertaken only by competent working personnel.





- Safety nets should not be stretched taut when erected, but should have an initial sag of between a quarter to a fifth of the length of the shortest side of the net. Safety net will deflect when arresting a falling body and requires a minimum clearance below.
- Safety nets should be fitted as close to the working surface as possible, and in no case further below than the maximum distance marked on the label attached to the net which would be either 1m or 6m. The gap between a net and the building should be as close as practicable but in no case should this be more than 200 mm.
- Safety nets should not be stretched taut when erected, but should have an initial sag of between a quarter to a fifth of the length of the shortest side of the net.
- A safety net will deflect when arresting a falling body and requires a minimum clearance below.
- The clearance should be equal to two-thirds of the length of the shortest side or 2 m minimum in order to prevent the contact with any surfaces or structures below. Members supporting the safety net should be adequate in both the horizontal and vertical directions at the net perimeter to resist the fall. A safety net must be inspected at regular intervals and after any fall. Test cords included in the net should be regularly tested in accordance with the recommendations made by reputable national or international standards.
- The use of safety harnesses is preferred to safety belts. The anchorage points should be as high as possible above the working position in order to limit the height of any fall. In some work activities, inertia reel may also be used. Safety harnesses/belts should be worn and fitted correctly. They should be regularly inspected and maintained in good serviceable condition in accordance with the manufacturers' instructions. In using safety harness or belt, appropriate anchorage and suitable standards of safety harness/belt of national or international standards should be adopted





Maintenance of chiller room and water tank

Cooling towers spray water through the air. As the process is highly oxygenated, it can become corrosive to metal piping and system components. Corrosion products from this process can foul and clog the system to the point where it will cease to function properly. Cooling towers can also become breeding grounds for fouling growth of algae and bacterial slimes that can interfere with equipment efficiency and operation. They can even become the sources of organisms that can threaten human health and life.

The maintenance of chiller room, water tank and ancillary equipment is one of the most common items on the daily agenda for facility managers and property owners. Most if not all of the duty holders discharge their duties or leave this important task to the specialist contractors, general electrical, water and air-conditioning repairers etc.

A number of these jobs are frequently left with subcontractors, small companies, inexperienced apprentices unaccompanied by competent personnel or even individuals without any formal training, qualifications and trade experience.

Workers engaged in maintenance are often faced with the hazards and issues arising from the following:

- Working at height
- Electrical installations
- Confined space
- Handling of contaminants and wastes
- Handling of chemicals and biocides

To improve the situation, the following areas should be looked into:

- Lock out system
- Personal protective equipment
- Good housekeeping
- Risk assessment
- Safe system of work

For some systems still using asbestos containing materials, such as lagging, insulation coating and painting, gaskets, fuse holders, etc., proper asbestos removal procedures must be strictly adhered to.





Cooling towers

Biological growth, scaling, and corrosion are the main maintenance concerns with cooling towers. Typical treatment involves the application of chemicals such as chlorine, sulfuric acid, phosphorous, and zinc compounds. Care must be taken in the storage, use, or discharge of these chemicals. Also it is necessary to ensure that the proper mixes and proportions of chemicals are used, and to determine the corresponding blowdown rates. Excessive application can increase the possibility of corrosion and other undesirable impacts. Ozone is beginning to gain acceptance in the industry as a viable biocide alternative.

Cooling tower water is continuously exposed to airborne organic materials, and the buildup of bacteria, algae, fungi, and viruses presents hazards to the tower system and to the health of workers engaged in regular maintenance work.

Guideline on health issues:

- Water cooled towers should be periodically maintained.
- Select suitable disinfectant and biocide for removal of dirt and organic growth, e.g. algae and slime. Appropriate tests should be conducted to make certain that the active detergent/disinfectant being employed is present in proper amounts at the end of 24 hours.
- Any “slug” of dose recommended by the manufacturer for disinfectant or biocide used to control growth should be performed during the operation of the system. This would be in addition to, and compatible with, the normal water treatment programme.
- For good engineering practice, fan-coil units and air handlers should be equipped with an approved biocide feeder to inhibit bacterial growth, prevent clogging of the condensate drain system and prevent odors.

Operation and regular routine maintenance

For the correct operation and regular routine maintenance of cooling towers, air-handling systems and hot, warm and cold water systems, etc. the minimum requirements are as follows –

- Water systems should be disinfected, drained, cleaned and then disinfected again when the installation:
 - is being started up for the first time;
 - has been out of use and has not been dry; or
 - has been extensively modified or disturbed.





- Cleaning may also be necessary at regular intervals if the system, the premises or the results of monitoring indicate that it is necessary to do so. In such cases, it is important to ensure that all parts of the system are disinfected, not just those which are readily accessible.

Some cleaning methods may create large amounts of spray (i.e. high pressure water jetting). If this cannot be avoided, and particularly if cleaning is done in confined spaces, then the personnel should wear air-line or self-contained breathing apparatus (SCBA) unless it is not safe or practicable to do so. This is recommended as filter respiratory protective equipment has not been specifically tested for use against aerosols containing bacteria that may put the workers' safety and health at risk.

Other ways to reduce the risk to maintenance personnel include decontamination and routine cleaning of cooling towers by chlorination of the tower water prior to any physical cleaning being undertaken.

Proper systems are necessary to minimize the risk of scalding and to reduce the health risk associated with the storage of warm water. These may include heat exchange systems, ultraviolet light systems, anti-scald safety valves and self-draining valves.

Cooling water systems should be provided with automatically regulated water treatment systems for effective management of corrosion, scaling, fouling and microbial growth.

The effectiveness of the water management system (including water treatment) should be assessed at least monthly.

The employer's responsibilities are not absolved by contracting out the maintenance, cleaning and testing. Employers should monitor the contractor's performance.

General operation and maintenance procedures

To reduce contamination of cooling towers, air-handling systems and hot, warm and cold water services, attention must be paid to their design, operation and maintenance procedures. In particular, always refer to the recommendations supplied by the manufacturers on the safe operation and procedures for preventive maintenance. The aim is to minimize the growth of micro-organisms in artificial environments and, if possible, to reduce the likelihood of inhaling any potentially contaminated aerosols.





For major replacement of systems, attention should be given to:

- design of enclosures;
- location of building air inlets, including windows which can be opened;
- direction of prevailing winds and any localized wind patterns;
- height and design of adjacent structures;
- proximity of other discharges such as kitchen exhausts; and
- future planned developments.

Design features should facilitate cleaning, control bacterial growth and minimize drift carryover. Attention should be paid to:

- provision for shutdown for maintenance;
- convenient and safe accessible openings for maintenance;
- components which minimize corrosion and can be easily removed;
- minimal internal components such as structural brackets which can collect sediments;
- materials compatible with the use of disinfectant and hosing with water jets;
- sumps that can be readily drained away;
- efficient drift eliminators;
- surfaces which can be readily cleaned;
- protection of wetted surfaces from direct sunlight; and
- adequate standby facilities where continuous operation is necessary.

The commissioning, operating, maintaining, cleaning, decontamination and other procedures should be designed to minimize the risk to personnel working on or in the vicinity of cooling towers and other potential sources of bacteria. The installations should be examined under normal working conditions for signs of microbial growth, algae, water leaks, splashing and blockages or restrictions at air inlets.

If aerosol sprays are created, the installation should be switched off when inspecting or carrying out maintenance. If this is not practicable, then particular filters, or equivalent respiratory protection should be worn to minimize the risk of inhaling water droplets contaminated by bacteria.

Maintenance of manuals and records

The operating and maintenance specifications and manuals provided by the manufacturer, designer, supplier or importer should be kept and made available for use. Maintenance records should also be kept and made available for inspection.





The operating and maintenance records should include:

- physical details, including drawings, of the equipment and systems;
- manufacturers' recommendations on maintenance, including water treatment maintenance and management;
- recommended cleaning methods and dismantling instructions;
- operating and shut-down procedures;
- date, item of equipment or system and nature of service performed; and
- the name of the person or company performing the service.

Safety training

Workers carrying out maintenance and water treatment should undergo in-house training to achieve an appropriate level of knowledge. The training should include:

- operations of cooling systems;
- principles of water treatment;
- maintenance of records;
- safety precautions; and
- relevant legislations.

All workers carrying out maintenance of cooling towers should be informed of the health risk associated, and instructed on the proper use of personal protective equipment. The minimum equipment needed to protect the worker from exposure to potential hazards should be provided according to the type of job being performed.

Asbestos

Asbestos containing materials were commonly found in construction materials. In recent years, the situation has greatly improved. One of the major reasons is that more and more old buildings have been demolished. Today, workers have less chance of being harmed by this hazard in the maintenance of these structures due to tighter regulatory control and workers' better awareness, proper training, adequate information and effective publicity.

Workers engaged in maintenance works are particularly vulnerable to the hazards associated with the materials being handled. In the past, Hong Kong had used asbestos extensively in –

- heat insulation building materials, such as:
 - roof tiles, balcony grilles, corrugated cement sheets (commonly used for roofing).





- chimneys and flues
- floor tiles, insulation treatment, paints, used in waterproof building materials.
- boilers and steam pipes, used in power plants, gas generation plants, kitchens, hospitals, hotels, sauna, etc.
- building materials for acoustic purposes, used in cinemas, entertainment halls, concert halls, school halls, acoustic ceiling and floor coverings
- heavy plants and vehicles used in construction projects, such as clutch/brake linings, waterproof treatment, heat insulation parts, etc.
- asbestos containing materials also found in insulation, dielectric parts, heat insulation components found in electrical equipment, e.g. fuse cartridge coverings, etc.

A Code of Practice (COP) on '*Safety and Health at Work with Asbestos*' issued by the Commissioner for Labour under Section 7A(1) of the Factories and Industrial Undertakings Ordinance (Cap 59) provides practical guidance in relation to the provisions of the Factories and Industrial Undertakings (Asbestos) Regulation

The COP covers the safe practices for handling, repairing or removing the following commonly encountered asbestos-containing-materials groups:

- asbestos-containing friction materials;
- asbestos-containing cement products;
- asbestos-containing coating and insulation;

It also provides guidelines on the necessary measures to protect workers from exposure to asbestos dust at work, such as

- Respiratory protective equipment,
- Assessment of work
- Notification
- Hygiene and safety requirements
- Storage, distribution of loose asbestos and waste
- Labeling of container and articles

Control measures include:-

- Suppression of dust by wetting, by other materials, or by extraction at source.
- Total enclosure at source with dust extraction system incorporating HEPA filter.
- Partial enclosure.





Systems of work

In construction activities, contact with asbestos usually relate to the removal of materials containing asbestos in existing buildings or structures. In these process, exposure should be reduced as far as reasonably practicable by:

- removing materials containing asbestos before any other work begins;
- adopting work methods that minimize breakage, abrasion, sanding, grinding or cutting of materials containing asbestos;
- suppressing dust by wetting where appropriate;
- avoiding carrying out asbestos work together with other work in the same place at the same time;
- segregating the asbestos work area from other areas; and
- keeping the work area clean by promptly removing off-cuts, waste and debris.

It is the responsibility of the proprietor or contractor to ensure that the work does not involve any asbestos-containing material. Asbestos specialist contractors should be engaged and the safety measures should be taken in accordance with the provisions under the Factories and Industrial Undertakings (Asbestos) Regulation.

When work is to be carried out in certain work sites which are subjected to special regulations and working practices, e.g. power stations, gas installations, marine installations, container terminals and chemical works, additional safety requirements or permit to work systems might be required as agreed with the site management.

The safety of working personnel engaged in other activities within the working area should also be considered in the site safety assessment.

Source of electricity

For maintenance work, the source of electricity must be handled properly and in a safe manner, otherwise it may lead to accidents causing serious bodily injuries or even deaths. To overcome this, workers engaged in electrical maintenance work must implement and follow a safe system of work.

A Guidance Notes on “*Safety at Work for Maintenance of Low Voltage Electrical Switchgears*” published by the Labour Department provides general practical guidance to workers engaged by electrical contractors, self-employed electrical workers, supervisors and other workers engaged in electrical switchgear maintenance work to enable them to carry out such work in a safe manner.





Low voltage (110V) for portable tools



Well placed and designed weather-proof switch box.



Duties of the proprietor

Time and again, accidents occurred to qualified professional engineers and technicians while working on switchgears and switchboards. These fatalities could have been avoided. Often, as switchgears, switchboards, and facilities so on are upgraded, or various parts and gears replaced, the circuits, operation procedures and specifications from the manufacturers are also altered as a result, but the work procedures and rules have not been updated. Furthermore, information and training on these new or upgraded systems are frequently not available for use.

Duties of a proprietor include:

- to manage safety and health in the workplace;
- to ensure that the responsibilities for managing safety and health are





assigned and actually carried out;

- to assess the risk and establish appropriate safety measures;
- to provide and properly maintain suitable and safe plant and equipment;
- to establish safety rules and safe working procedures;
- to provide information, instructions and training to the workers;
- to ensure that the safety rules and safe working procedures are followed;
- to appoint registered electrical contractors;
- to employ only qualified and experienced workers;
- to employ only registered electrical workers to carry out the electrical work;
- to establish emergency response plans and conduct drills regularly.

Duties of the Workers

Workers are required to take reasonable care for the safety and health of themselves and of others who may be affected by their acts or omissions at work. They are also required to co-operate with their proprietors or the management personnel so far as is necessary to enable them to comply with the legal duties imposed on them.

The duties of a worker include, but not limited to, the following:

- to understand and act in accordance with the safety rules, safe working procedures and emergency response plan;
- to make full use of the safety equipment and personal protective equipment provided, and to report any equipment defect to the management/ supervisor immediately;
- to provide feedback to the management/supervisor on the effectiveness of safety measures, safe working procedures and emergency response plans; and
- to report to the management/ supervisor all hazards observed, defects identified or accidents that occurred at work.

Hazards and risk Assessment

The hazards in electrical switchgear maintenance work can be broadly grouped into the following major categories:

- Electrical shock hazards;
- Fire and explosion hazards; and
- Other related hazards.



**Electrical shock hazards:**

- Workers are vulnerable to electric shock hazard whilst working on the conductive parts of the electrical switchgear which has not been properly isolated from the power source.
- Electric shock hazard also arises from the improper application of high voltage test on the electrical switchgear.
- Electric shock can cause serious injury or even death to the worker due to cardiac arrest, respiratory arrest or body burn.

Fire and explosion hazards:

- Fire and explosion in electrical switchgear maintenance work can be caused by accidental short-circuit of live parts and earthed parts by, say, metal hand tools, substandard testing equipment, loosened parts or foreign objects left inside the switchgear after work.
- Fire and explosion of the switchgear can cause serious injury or even death to the workers due to severe body burn caused by the hot gas mass or molten metal, inhalation of smoke caused by the fire, or eye injury caused by the intensive light and ultra-violet radiation generated by electric arcing.

Other related hazards:

There are other hazards that relate to electrical switchgear maintenance work. These include, but not limited to, the following:

- hazards related to the falling from height of workers when working on electrical switchgear installed at high levels;
- tripping hazards due to tangling of electric wires of portable tools or loose hand tools placed on the floor; and
- musculoskeletal problems resulting from manual handling of heavy objects such as air circuit breakers or prolonged periods of awkward postures.





Safety before work

- Brief the workers on-site with details on scope of work, the works programme, job duties of the individuals, special precautions, the safety rules or procedures, etc.
- Check the working environment and ensure that the place is safe.
- When the work starts, the equipment should be rendered dead. Relevant switch/isolator should also be locked out, if not, fence it off and erect a warning sign.
- Before working on live parts, discharge all energy possibly stored
- For particular situations, warn the workers to stay away from the exposed live parts, and erect suitable safety precautions. Identify the live part and adopt a permit-to-work system.

Safety during work

- Prohibit unauthorized personnel from the work area.
- Follow agreed procedures especially during re-commissioning of the system. Workers are particularly vulnerable as switchgears and equipments are becoming energized again in steps.
- If the switchgear/switchboard is under testing pending re-commissioning, special precautions should be followed on the re-energized live parts.
- If it is unavoidable to work on or near a live electrical installation, workers should use, in addition to all other safety measures, protective equipment, such as insulated gloves, insulated mats, insulated screens, insulated clothing etc., of a suitable type and grade for the work. Hand tools for work such as spanner, screwdriver etc., should also be of the insulated type.





Safety after completion of work

- Upon the completion of work and before re-energizing the electrical switchgear/switchboard and putting it back to service, it is necessary to ensure that:
 - the equipment, meters, devices, etc. of the switchgear/switchboard are restored to correct working conditions and settings;
 - all tools, equipment and materials for work have been removed from the electrical switchgear/switchboard;
 - all covers, panels and doors of the switchgear/switchboard are replaced properly and locked tight;
 - follow the procedures when carrying out the switching work, preferably with minimum staff staying inside the switchroom; and
 - no one except the designated competent person should carry out the switching operation.

Emergency preparedness

- Emergency response procedures should be established.
- The location of emergency exits and evacuation paths should be announced. Re-check these exits and evacuation paths and ensure that they are in serviceable conditions and unlocked.
- Provide fire extinguishing appliances.
- Adequate devices, e.g. telephone, should be made available for calling the emergency services in the workplace or its vicinity.
- Provide information and training to workers on how to isolate the supply in case of emergency.
- Get a worker in the working team and train him in first aid and cardio-pulmonary resuscitation (CPR) in case of electric shock or explosion.

General safety and health training

All persons involved in the electrical switchgear maintenance work should be fully trained in the safety and health aspects of the work under normal operation as well as in emergencies. The general safety and health training should cover:

- hazards in electrical switchgear maintenance work;
- relevant legislation and responsibilities of the persons concerned;





- equipment and safety devices for the work, including their uses and limitations;
- safety measures, including the selection and use of safety equipment and personal protective equipment, and their limitations;
- general safe practices for the work;
- emergency response and procedures including evacuation plan;
- general examination and maintenance of equipment, pre-use and after-use equipment checks; and
- build up good co-ordination with other workers and the awareness of taking care of other persons during their course of work.
- safety at work for maintenance of low voltage electrical switchgears

Emergency rescue equipment

For working or rescue operation, fresh air intake is vital

Tripod fitted with winch designed for personnel rescue.





CHAPTER 7

Renovation Work and Refurbishment



In major renovation work and refurbishment projects, contractors are usually less concerned with putting a more comprehensive safety management system in place to deal with the safety issues. In the case of small scale renovation work, contractors' competencies vary from experienced and competent hands, similar to contractors for new building projects, to the smaller establishments or the less experienced individuals who take on make-shift odd jobs when they are, technically or professionally not qualified to do the work. If the employers leave their jobs to these individuals, they will be failing to ensure the safety and health of their workers.

Irrespective of the scale of work, it is the duty of proprietors/employers to ensure, so far as is reasonably practicable, the safety and health at work of persons employed by them. They have a statutory duty under Section 6A of the Factories and Industrial Undertakings Ordinance, to look after the safety and health of workers working in renovation/refurbishment work.

Working with solvents and paints

Like any chemicals, solvents and paints are frequently used in worksites, especially during renovation and refurbishments. Quite a number of the solvents and paints are dangerous substances by nature. Some of these are hazardous when heated, grounded or mixed with other chemicals. Sometimes, even pouring chemicals from one container to another may be hazardous.

Without adequate knowledge of the hazards or in the absence of appropriate precautionary measures, accidents may occur, leading to casualties.

Depending on the properties of the solvents and paints used, the way they are used and the place they are used and applied, the hazards vary with the reactions and





processes involved. Especially in the cases of solvents in contact with air and in mixing, the hazards can be out of control if not properly managed by competent workers.

General precautions to ensure safety and health at work are:

The Hazards:

- fire and explosion
- harmful and toxic gases or harmful airborne particles
- unstable, hot, corrosive or toxic liquid
- health problems such as ulcer, intoxication and even death. These can affect the offsprings of the affected workers

Basic steps in the safe use of solvents and paints

Identify the hazards

- The hazardous properties of the solvents and paints involved
- The reaction and the products when solvents and chemicals are in use,
- The effect to the environment

Safety measures

- Select safer substitutes.
- Use engineering control measures.
- Wear appropriate personal protective equipment.
- Understand and follow safe operating procedures.
- Understand contingency measures, and in case of accident, follow emergency procedures.

Safety information and hazard identification

- Refer to the material safety data sheet (MSDS).
- Obtain information from suppliers/manuals or chemical safety handbooks.
- Before use, identify the hazardous properties and the possible hazards involved.
- Take appropriate safety measures.





Control measures and personal protective equipment

- Use engineering control.
- Personal protective equipment, to be used as the last resort.
- Keep the work area well-ventilated.
- Work under local exhaust ventilation whenever possible.
- Prohibit all ignition sources.

Other precautions

- Don't touch solvents and paints with bare hands. Wear protective gloves.
- Don't try to suck solvents and paints with your mouth. Use appropriate liquid delivery tools.
- Don't use container with narrow opening as it traps heat and/or gases.
- Don't mix oxidizing agents with flammable/combustible substances.
- Don't eat, drink and smoke while using solvents and paints.

Paint spraying and solvents/paints handling

During spraying, the solvents and paints in aerosol form may enter the human body by inhalation or skin contact. If it is a toxic/harmful/irritating substance, it will be injurious to health. Propellants used in common aerosol cans are flammable substances. If the solvents and paints being sprayed is a combustible substance, the aerosol of the substance may form flammable mixtures with air. The flammable mixtures will catch fire in the presence of an ignition source, which can even lead to explosion.

Safety precautions

- Prohibit all sources of ignition.
- Operate under local exhaust ventilation to vent away the hazardous aerosol as far as practicable. If this is not practicable, then work with less hazardous substance for shorter duration and ensure that the place is well-ventilated.





Special hints for maintenance paint work:

The following key performance factors are:

- Compatibility – this avoids stripping in order to change paint systems. Stripping involves large grit usage, often resulting in safety, health and environmental issues;
- Durability – provides good surface adhesion;
- Patching – provides a repair mechanism with the best safety, health and environmental profile.

Before deciding on the best option, safety, health and environment factors must be considered. These include –

- continuing patching with the existing paint, which indefinitely postpones stripping and repainting, leading to much lower emissions not just for VOC but across a wide range of other environmental impacts;
- compatibility, durability and patchability are the key factors in identifying the best maintenance paint system for the sake of safety, health and also environment;
- stripping and repainting produce a range of safety, health and environmental burdens.

Applying different solvent applications needs specialist knowledge of the process, including weighing complex technical options. Inevitably it must be a balance of safety, health, performance, quality, cost and environmental concerns.

Special hints for handling spills

Should a spillage of paint or solvents occur, the following procedures should be followed –

- If the spill is of a major nature, the relevant government department such as the Environmental Protection Department, the Police and the Fire Services Department should be contacted immediately.
- Do not allow spilt material to enter drains.
- Absorb spilled material with sand, earth or other absorbent material. Collect and seal in properly labeled drums for subsequent disposal in an approved facility.
- Ventilate area to remove fumes.





Special hints for tank painting:

Most coating products designed for use as tank linings contain flammable organic solvents. Definite safety precautions must be taken whilst applying these coatings in the confined interior of tanks. Attention must be given to –

- Danger of explosion or fire
- Provision of a suitable breathing environment
- Prevention of skin irritation problems

Proper PPE



Storage, applying, mixing, etc. of paints, primers, anti-rust coating, chlorinated rubber coatings, lead based colour coating, solvents containing lead pigments or compounds and epoxy coatings and other chemical bonding compounds commonly found used in worksites

(Source: OSHC)



Proper labelling

Proper protection by using PPE during varnish removal





Special precautions and suitable PPE when using two-component epoxy and enamel coatings, designed for the protection of floors, concrete, steel, iron and wood



Adhesive or other bonding compounds used in carpet laying or polyurethane coating in wooden flooring



Others may include chemical compounds applied in expansion joints

Chemicals used and mixing in worksites, e.g. compounds used in waterproofing works, applying acoustic layers in confined areas, paint strippers, etc.



Oil-based and water-based (latex) paints using petroleum-based solvents may produce volatile organic compounds (VOCs), or smog-producing ingredients





Air impurities may be released from the process such as cutting in the worksites. Chemical vapours may also release pollutants into the air when they are being cut, used or stored, e.g. cutting plywood, timber boards, acoustic boards, PE/PP boards commonly used in renovation and building worksites.

(Source: OSHC)



Loads on scaffolds

Design of scaffold

Scaffolds in renovations work and refurbishment project should be designed with safety in mind. This approach makes it possible to eliminate or minimize the work hazards, namely by proper planning and design of the methods of construction, sequence of activities, coordination, etc.

During the design of a bamboo scaffold, attention should be paid to the following areas:

- The safe scaffold and its erection/alteration/dismantling for different stages of construction should be designed and planned well beforehand.
- The method of scaffolding used should be kept under continual review.
- The strength and stability of the scaffold should be ensured throughout all stages of work.
- The strength of scaffolding members such as bamboo and log should be ensured.
- A realistic assessment of loadings on the scaffold at all work stages should be made. In considering the wind load on the scaffold, reference should be made to the Code of Practice on Wind Effects, (Hong Kong, 1983 or its latest edition). Regarding the loads on working platforms, all decking units of working platforms should have adequate strength to meet the recommendations made by the Labour Department (see table below).
- Safe access to and egress from the working places should be provided.
- Additional features such as attachment points for ladders, working platforms, guardrails and toe-boards should be provided for the protection of workers using the scaffold.





- Safety nets and safety belts should also be provided for the protection of the scaffolders.
- Scaffolding components/materials/equipment should be handled, lifted, stored, stacked and transported safely.
- The timing for erecting and dismantling should be decided in the design and planning stage.
- The scaffold should be dismantled as soon as it is no longer required to be used.

Load Table (from the *Code of Practice for Bamboo Scaffolding Safety* issued by the Labour Department)

Minimum Imposed Loads			
Duty	Use of platform	Distributed load on platform	Concentrated load to be applied on plan over any square with a 300mm side and at the end portion of a cantilever
Inspection and very light duty	Inspection, painting, stone cleaning, light cleaning and access	0.75 kN/m ²	2 kN
Light duty	Plastering, painting, stone cleaning, glazing and pointing	1.5 kN/m ²	2 kN
General purpose	General building work including brickwork, window and mullion fixing, rending, plastering	2 kN/m ²	2 kN
Heavy duty	Blockwork, brickwork, heavy cladding	2.5 kN/m ²	2 kN
Masonry or special duty	Masonry work, concrete block work and very heavy cladding	3 kN/m ²	2 kN

Specifications for scaffolding contract:

- Specification for scaffolding contract document should incorporate particular requirements and essential information for the scaffolding work to be planned and undertaken safely. (For example, the provision of design drawings and method statement; phasing of work, particularly the interfacing with other contractors; periodic maintenance and repair of scaffolds.)
- Special requirements relating to compliance with safety legislation should be highlighted and, where appropriate, these items should be included in the Bills





of Quantities.

- Depending on the size of the project and/or the complexity of the work involved, tenderers for the scaffolding work should be required to submit an outline scaffolding plan at the tendering stage, giving sufficient information to demonstrate their intended safe system of work.

Coordination and communications:

- There should be close liaison between all relevant parties even at the design and planning stage.
- Effective lines and systems of communication should be devised for each stage of the scaffolding work and a person should be assigned to maintain effective communication.

Initial planning:

- Site considerations and risk assessment

Potentially hazardous site features and other aspects likely to impair safe scaffolding should be identified. The risk arising from each individual hazardous event should be evaluated according to its probability and consequence.

The following special conditions of the site should be taken into account:

- The existence of overhead electric power lines.
- The existence of overhead signboards or projections, particularly those in the urban areas.
- The existence of buried services, including underground electric cables, gas or other fuel pipelines.
- The existence of storage tanks.
- Restricted access to and onto the site.
- Restricted space for erection, maneuvering, storage and, if required, for on-site pre-assembly or fabrication.
- Low ground bearing pressures that may be due to, for example, ground or existing underground services or structures.
- The proximity and condition of other buildings and premises that may, by itself or by induced special wind effect (for example, funneling effect), affect the planned method of scaffolding.
- The shape and the structure of the building.
- The juxtaposition of the public and the site.
- The activities of other contractors.
- The existence of noxious gases, chemicals, fluids or dust emitted from processes on or around the site.





- Preliminary method statement

Where appropriate, a preliminary method statement should be prepared which should include:

- the arrangements for coordination and the responsibilities and authority of supervisory personnel during scaffolding work;
- the scaffolding sequences including erection and dismantling;
- the methods of ensuring stability with due consideration of future construction activities (for example, trench work, external building services/facilities installation);
- the detailed scaffolding work method which should ensure that the work could be carried out safely;
- the construction tolerance;
- the assessed maximum allowable loading (includes vertical and lateral loads) on the scaffold/working platform;
- the provisions to prevent falling from height, including safe means of access and egress and safe places of work;
- the protection from falls of materials, tools and debris, and the provision of catch-fans and protective screens at the scaffold;
- the provision of suitable plant, tools and equipment;
- the arrangements for delivery, stacking, storing and movement on site for scaffolding components, materials and equipment;
- the details of site features, layout and access; and
- the contingency arrangements.

Site management and procedures

In managing the erection/alteration/dismantling process, the safe working methods and practices on site should include the following –

- Preparation and use of a detailed method statement.
- Thorough and active contract coordination both on and off site
- Implementation and maintenance of effective communications.
- Contingency plan for adverse weather conditions.
- Provision of competent supervisors and skilled workers.
- Provision of suitable personal protective equipment.
- Preparing the site and the work.
- Plans and drawings before work commences.
- The need to exclude other personnel from scaffolding areas when scaffolding work is in progress.





- Site inspection to check on the physical conditions, the hazards involved and other special features.
- The ground condition to be made firm, level and suitable.
- The maximum safe loading (includes vertical and lateral loads) imposed on the scaffold should be assessed, and strictly adhered to.
- The bamboo members to be checked for their fitness before despatching to the site. Defective materials should be prohibited for use and removed from site as soon as possible. During their keeping on site pending for removal, they should be properly identified and set aside.
- A suitable place to be provided at the site for storage of bamboo members and the associated materials, tools or equipment. The storage area to be clearly shown on the site plans. The bamboo members to be stored in dry area and in vertical position to prevent the accumulation of wastewater inside, thus causing them to decay. Also, they should be properly stacked and tied to prevent accidental displacement and collapse.
- Documents such as scaffolding plan, method statement, design drawings and specifications of the scaffold, etc. should be made available to all parties concerned in good time.

Technical safety requirements in bamboo scaffolding

General requirements on the selection of materials:

- Sufficient materials should be provided for and used in the construction of scaffolds.
- Scaffolding components should be of sound material, good construction, adequate strength and free from patent defects, and should be properly maintained.
- Timber (such as fir) so used should be of sound construction, adequate strength and free from patent defects.
- Boards and planks used in the construction of working platform should be straight-grained and free from large knots, dry rot, wormholes and other dangerous defects. Where necessary, they should be protected against splitting.
- These boards and planks should be unpainted so that any defects are readily visible.

General requirements on the support for bamboo scaffold

- The ground or structure on which a scaffold is constructed should be solid, leveled and rammed to give a hard surface, and should be strong enough to keep the scaffold upright.





- The stability of the ground or supporting structure should be justified by recognized engineering principles. The soil should be compacted or consolidated and as far as practicable, water should be drained off.

Woodworking

Woodworking machinery used in renovation and refurbishment trade are usually more portable and easy for installation and un-installation. In recent years, more and more finished or semi-finished wooden furniture and fittings are used instead of tailor-making them. Only on site fitting or painting/varnishing, minor touch up, etc. involve woodworking. However, there are still accidents arising from the handling of circular saws. Most of the injuries inflicted are relatively minor in nature, ranging from amputation of fingers to minor cuts.

In many worksites, portable circular saws are being mounted onto a tabletop converting its use as a bench-type circular saw. For safe practice, relevant safety requirements in the woodworking machinery should be followed.

General safety of circular saw

The part of a circular saw below the bench table should be protected by fencing it with two plates of metal or other suitable material. The two plates should not be more than 150 mm (6 inches) apart and should extend from the axis of the saw outwards to a distance of not less than 50 mm (2 inches) beyond the teeth of the saw. In addition:

- The metal plate, if not beaded, for fencing the part of a circular saw below the bench table should be of a thickness at least equal to 2 mm.
- The metal plate, if beaded, for fencing the part of a circular saw below the bench table should be of a thickness at least equal to 1 mm.
- A riving knife should be fitted in direct line behind the circular saw.





- The riving knife should have a smooth surface.
- The riving knife should be strong, rigid and easily adjustable.
- The riving knife should so positioned that the edge of the knife nearer the saw shall form an arc of a circle having a radius not exceeding the radius of the largest saw used on the bench.
- The riving knife should be maintained as close as practicable to the saw and be so positioned that the distance between the front edge of the knife and the teeth of the saw does not exceed 15 mm (0.6 inch).
- The riving knife for a circular saw of a diameter of less than 600 mm (24 inches) should extend upwards from the bench table to within 25 mm (1 inch) of the top of the saw.
- The riving knife for a circular saw of a diameter of 600 mm (24 inches) or more should extend upwards from the bench table to a height of not less than 250 mm (9.8 inches).

Fencing of circular saw

- The top of a circular saw should be covered by a strong and easily adjustable crown guard with a flange at the side of the saw further away from the fence.
- The crown guard should be kept so adjusted that the flange shall extend below the roots of the teeth of the saw.
- The crown guard should extend from the top of the riving knife to a point as low as practicable at the cutting edge of the saw.

Push-sticks

A suitable push-stick should be kept available for use at the bench of a circular saw.

Starting/stopping device

A woodworking machine should be provided with an efficient stopping and starting appliance which should be readily and conveniently operated by the person in charge of the machine.





Floors, lighting, etc.

- The floor surrounding a woodworking machine should be maintained in good and level condition and free from chips and other loose material.
- The floor surrounding a woodworking machine should not be allowed to become slippery.
- Adequate lighting not less than 160 lux should be provided for a woodworking machine.

Circular saw without adjustable riving knife, a crown guard not in position, and emergency switch not installed



Portable saw converted to table saw with substandard safety features



Poor housekeeping leaving the surrounding floor unsuitable for working.





Top guard (crown guard) not properly adjusted and no 'emergency-stop' cut-off switch installed



Well protected circular saw

Emergency-stop control switch.

Fire extinguisher.



Properly designed circular saw

Emergency-stop control switch





Circular cutter used for cutting wood





CHAPTER 8

Demolition



The process of demolition is often considered as a reversal process of building. However, building plans and details of the buildings are often not available, either not handed over with the building by the builder or the building plans are too old to be traced. As a result, details of the specification and structural elements have to be established by subsequent survey, tests and examination.

To carry out demolition safely and economically, a great deal of experience and skills are required. The works should be carried out by competent contractors with extensive knowledge in old building technologies and practices.

In the past, there were instances that explosives, undetonated bombs, or other dangerous substances had been found during the demolition of basements or removal of old wooden piles from foundations. In such cases, it is advisable follow the emergency procedures and report to the Fire Services Department, the Police or other appropriate authorities.

There are many safety and health issues relating to demolition works, such as –

Noise

At present, concrete breaking using pneumatic breakers is the most commonly employed method in demolition projects. These breakers vary from truck-mount to hand-held. The noise level can be as high as 120 dB(A) or more. If more machines are employed to meet the scheduled programme, both the process control and location of the plant and process had to be carefully considered for the safety and health of workers working therein.





Considering the time in which the workers are exposed at a demolition site, noise hazard could be very significant. Unfortunately, engineering control seems to be very limited.

The selection of more environmentally friendly plant and breakers, suppressors and silencers on compressors and breakers, wetting of the materials, etc. should be considered to reduce the noise levels to a minimum level.

In addition, earplug and earmuffs should be provided and used by all workers exposed to the noise hazard particularly to those operating noisy machines and plants.

Plant and equipment

Plant and equipment should be regularly maintained. Faulty items not only generate high level of noise but also pose additional safety concerns to workers. Workers should report promptly and return the equipment immediately for repair. It should be taken away for service.

Personal protective equipment

Old building sites are potentially dangerous. The underground services are usually in poor repair state. Previous use of the site, such as factories, oil stations or depots, should be carefully assessed during the initial risk assessment. The underground soil may be contaminated with chemicals, flammable waste, e.g. diesels and grease, etc. and pose additional hazards to demolition workers.

Other materials, such as asbestos, asbestos containing materials, lead paint, dust or fumes, may be present, requiring proper selection of protective clothing, e.g. respirators, helmets, goggles, footwear, gloves, etc.

Projecting nails, pieces of metal, etc. resulting from demolition can also cause accidents.





Debris	Sections of the building must not be overloaded with debris either on suspended floors or against partition walls. Building debris should be cut into suitable sizes or loading pending removal from the site. Contaminated debris, e.g. asbestos wastes, should be packed and disposed of in accordance with existing regulations. The necessary permit and license should be applied well before commencement of works.
Weather conditions	Strong winds or heavy rain against unsafe walls, suspended floors etc. pose unexpected dangers. Use proper temporary structures or propping to avoid sudden collapse.
Flooding	Water build-up effectively reduces dust and/or noise but beware that it is also hazardous and can lead to failure.
Overhead cables	Excavators, cranes etc. must be checked against the height of any surrounding overhead cables to ensure safety of workers, avoid damage to plants and disrupting the power supplies of the neighbourhood, etc.
Scaffolding and hoarding	Scaffolding and hoarding must be constructed in accordance with the relevant regulations.
Public safety	The demolition site and any partially demolished buildings must be properly secured against unauthorized entry.
Dust	Should be kept to a minimum by spraying with water when necessary.
Supervision	A method statement showing how the demolition work is to be carried out should be prepared. The contractors should appoint a “competent person” who will supervise the demolition works throughout the process.





Demolition of slab and beam from ground floor

Hoarding to safeguard safety of workers and the public.



Good planning of debris removal of demolition waste

Separation of workers and mobile plants

Convey debris through temporary steel ramp



Demolition of the basement (special precaution of the enclosed noise)

Operator to be well protected against noise.





Reinforcement fixing for new cast B2 slab.

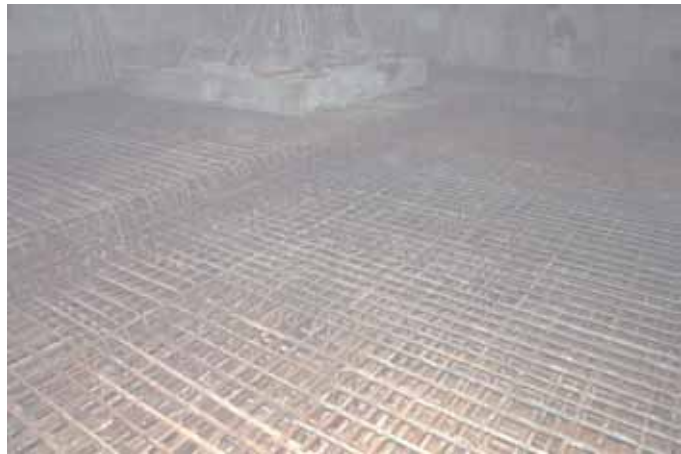

Install steel propping under slab & beam.



Erect temporary steel supports and bracings for existing basement wall.





Cautious removal with a gripper-like demolition tool (pre-fabricated buildings) to reduce noise and dust.



Watering of the working area to reduce the emission of dust and fibres.





Use of PPE in concrete removal.



General purpose PPE for demolition workers.



Debris removal.





Erect scaffolding with heavy duty net and canvas.
(Source: CIVCAL)



Erect canvas and catch fan.
(Source: CIVCAL)



Catch fan erected.

Props to guard against uncontrolled collapse.
(Source: CIVCAL)



Propping to support demolition plants.





Removal of debris.
(Source: CIVCAL)



Demolition plants in position.
(Source: CIVCAL)

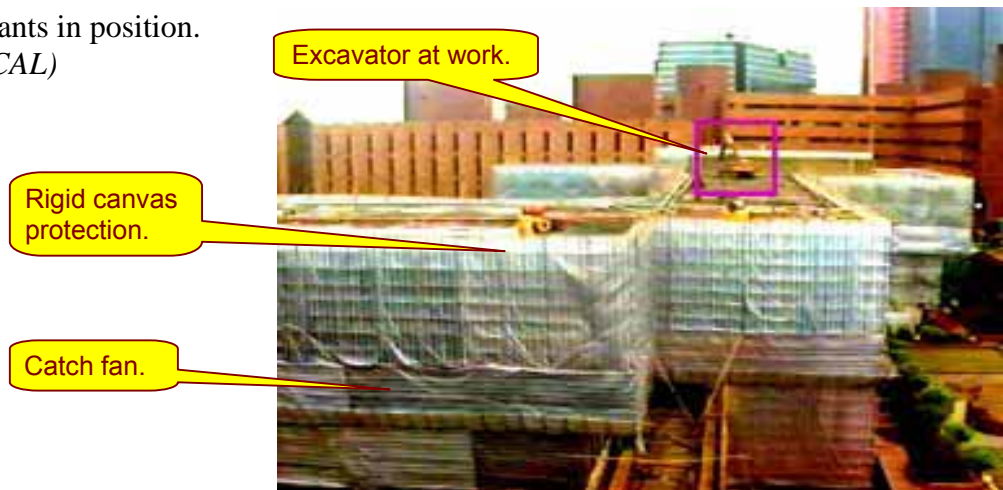

Demolition debris collection points.





Demolition debris collection chutes.

Safety net to guard against falling objects.

Chutes and canvas to avoid dust emission.





CHAPTER 9

Site Management



Handling of accidents and dangerous occurrences

Under Section 13 of the Occupational Safety and Health Ordinance, it is necessary to report to the Labour Department accident that occurs at a worksite involving death, or serious bodily injury, or incapacity of an employee for three days or more.

Serious bodily injury refers to a person's admission at a hospital or clinic for treatment or observation. The term "incapacitated" means that the injured worker is permanently or temporarily incapacitated from working in any capacity in which, but for the accident, the injured would have been capable of working.

A contractor should report in writing with the required particulars to an occupational safety officer of the Labour Department within 7 days after the date of the accident.

Particulars to be included in the report:

- The name and principal business address of the contractor;
- The name, residential address, gender, identity card number, age (if known) and occupation of the victim of the accident;
- Details of the activities at the worksite;

Particulars of the accident include whether death or incapacity has been confirmed, and the activity that the victim was engaged in at the time of the accident.

Under Section 14 of the Occupational Safety and Health Ordinance, a dangerous occurrence that occurs at a worksite must be reported, notwithstanding that the occurrence has been notified or reported in relation to the reporting of the accident.





A “Dangerous Occurrence” includes an occurrence of any event as described below:

- The disintegration of a revolving vessel, wheel, grindstone or grinding wheel that is operated by mechanical power.
- The collapse or failure of a lifting appliance, e.g. crane, derrick, winch or hoist, (except the breakage of chain or rope slings).
- An explosion or fire that –
 - causes damage to the structure of any workplace, or to any plant or substance or a workplace; and
 - prevents the continuation of ordinary work at the workplace.
- An electrical short circuit or electrical failure of electrical plant that –
 - is followed by, or associated with, an explosion or fire; or
 - causes structural damage to the plant, being a short circuit, failure, explosion, fire or damage that stops the operation of the plant or prevents it from being used.
- An explosion of a receiver or container used for the storage at a pressure greater than atmospheric pressure or of any gas or gases (including air) or any liquid or solid resulting from the compression of gases.
- A total or partial collapse of a roof, wall, floor, structure or foundation of premises where a workplace is located.
- A total or partial collapse of any overburden, face, tip or embankment within a quarry.
- The overturning of, or a collision with any object, by –
 - a bulldozer, dumper, excavator, grader, lorry or shovel loader; or
 - a mobile machine used for the handling of any substance in a quarry.

Within 24 hours after the occurrence of a dangerous occurrence, a contractor should report in writing to an occupational safety officer of the Labour Department. The report must include the following particulars –

- time of the dangerous occurrence;
- particulars of damage to, or the destruction of, property; and
- the circumstances of the dangerous occurrence.

Responding to emergencies

In the past, there were specific incidents in the course of building works, e.g. a bomb uncovered during excavation work, demolition of structures which were previously used or had been used as a dangerous goods store or petroleum installations. The following guidelines outline steps to take in response to some specific emergency situations.





Bomb threat or explosion

- Get out of the area as quickly and calmly as possible.
- In the event of falling debris, take a sturdy cover until the situation is stabilized enough for your safe passage. When it is safe, leave quickly and watch out for weakened floors and stairs.
- Ensure your own safety before trying to help others.
- If trapped in debris, do not light a match. Cover your mouth with a handkerchief or clothing. Tap on a pipe, wall or similar items to alert rescuers.

Fire

- Stay low to the floor, as the smoke, poisonous gases and heat will rise to the ceiling.
- Cover your nose and mouth with a wet cloth and protect any exposed skin area.
- Vacate the area as quickly and safely as possible and proceed to the agreed assembly area.
- Do not go through closed doors that are hot. There may be fire on the other side.
- If you cannot escape, hang a light coloured sheet out the window to alert rescuers of your presence.

Hazardous chemicals release

Hazardous chemicals can be released by accident. They range from toxic to highly toxic chemicals. Exposure could cause serious or fatal injury. Examine the situation to decide whether to stay and wait for rescue or to evacuate the area. If the chemicals are heavier than air, you may have to move to higher ground. For your safety, in all circumstances, listen to the advice from the rescue or emergency services.

Steps to take in case of a chemical spill:

- stay away from the scene
- attempt to get upwind of the contaminated area, and
- call the Fire Services Department.

If you believe a toxic chemical has been released in a closed space such as a basement, underground structures or inside a building:

- move away quickly to an upwind location nearby to avoid the spread of contamination and try not to inhale fumes





- call the Fire Services Department or 999 .
- if you have any of the chemicals on you or on your clothes, avoid touching your mouth and eyes, remove your outer clothing and do not leave the area.
- to assist emergency services to identify the chemical, keep track of your symptoms including your breathing, heart rate, perspiration, dizziness, blurred vision, skin tones and deliriousness, and report them to the rescue officers as soon as possible; and
- take precaution in helping others who may be contaminated as you may become affected.

Some useful hints to take when evacuating from the scene:

- Take the first aid kit and a mobile phone, if available, before leaving
- Leave as quickly as possible.
- Attend to the special needs of those less able and not as strong.
- Gather members of your gang, if possible, and go to the agreed meeting place.
- Use travel routes specified by emergency services. Do not use shortcuts to avoid danger.
- Stay away from fallen power lines.
- If you go to an agreed assembly point, report to the responsible person, e.g. the fire warden.
- Follow the instructions issued by emergency services.

Injury Management

A well-planned injury management system helps to avoid problems that may arise during the workers' compensation claims process. Such considerations cover the injured workers, the employers and the insurer on such matters as:

- payment of benefits
- effect of delays in treatment and payment of medical expenses
- return-to-work issues
- reporting of injuries.





Sometimes the worker or the employer may be unhappy about the medical treatment that the worker is getting. A second opinion can be requested from another independent doctor. The matter can also be referred to the proper authorities. If agreed upon, an approved medical specialist may be called in to examine the worker, review the medical records, and write an independent report, outlining the treatment that is required.

Voluntary Rehabilitation/Return to Work programme

The Working Group on Construction Site Safety and Employees' Insurance of the Provisional Construction Industry Coordination Board launched a trial 'Voluntary Rehabilitation and Return to Work' programme for injured employees of the construction industry in 2003. The programme provides rehabilitation services to injured employees by participating insurance companies to help them recover and minimize permanent damage. This will also enable them to return to work as soon as possible.

If properly managed, the following disagreements can be avoided –

- the injured worker refusing to accept the duties
- the injured worker disagreeing to the offer
- the treating doctor reluctant to agree to them
- the injured worker not making progress in the different – often lighter – duties provided to him upon return to work.

